

Alimak FC 6800-12 HS

Model 650 FC-S 31/39 Hi-Speed Single Car Construction Hoist

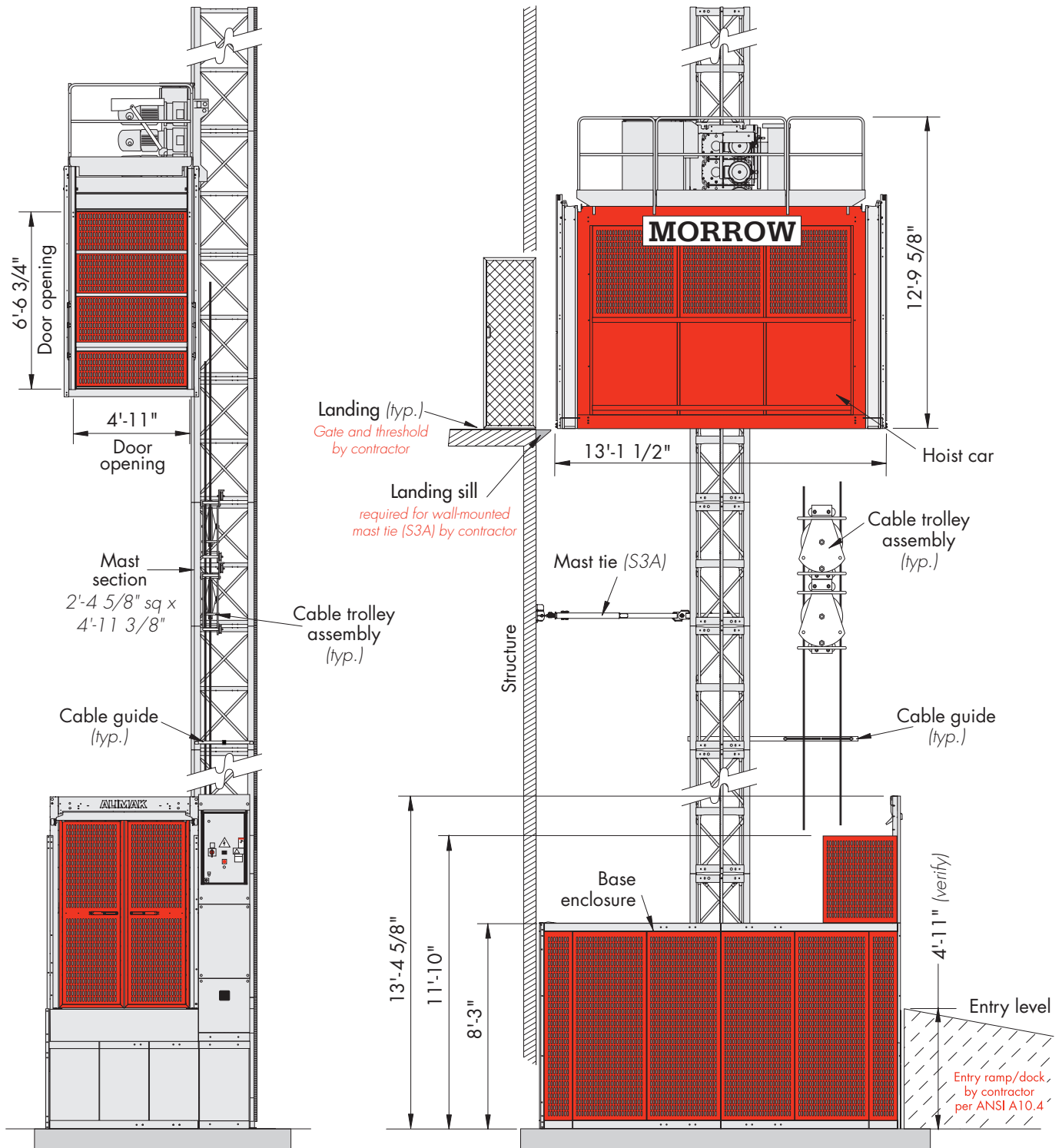

EN 12159
PDF 1209



Morrow Equipment

FC 6800-12 Hi-Speed Single

Foundation Details

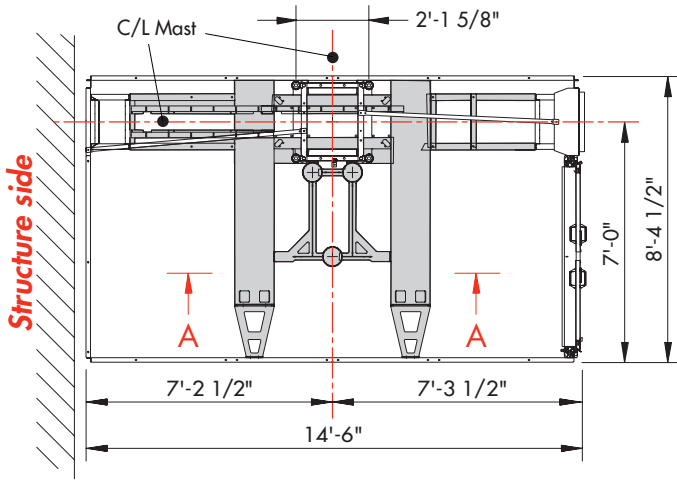

Plan View
Single base enclosure

IMPORTANT! Verify that the use of a slab foundation conforms to all applicable federal, state and local standards and codes **PRIOR** to foundation installation.

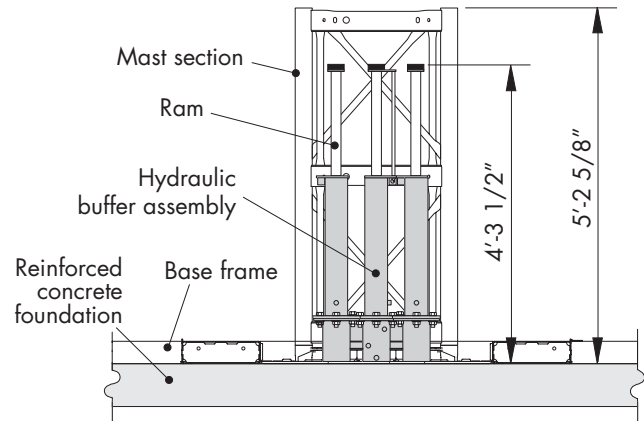

Mast Base
Section A-A

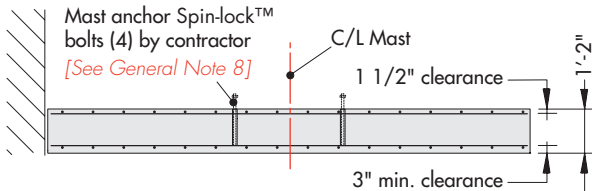

Elevation (Concrete footing)

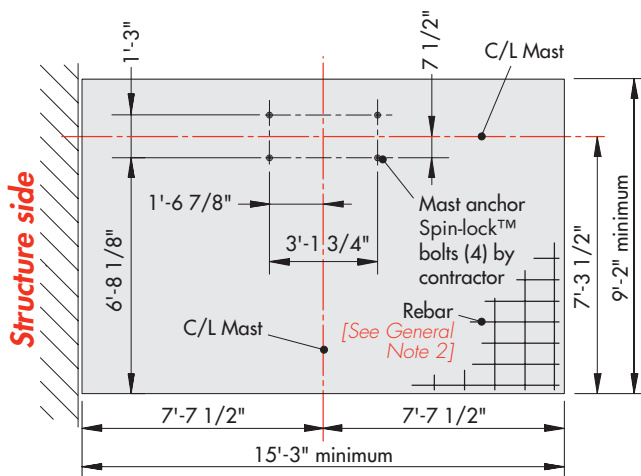

Plan View
Concrete footing

GENERAL NOTES

1. Foundation: 15'-3" x 9'-2" x 1'-2" with 3,625 psi concrete at 28 days.
2. Rebar: #5 ASTM A615-60. Top mat: 10" o.c. each way. Bottom mat: 10" o.c. width way and 7" o.c. length way. (See details in operations manual.)
3. Foundation based on 490-foot mast height. For greater heights, contact Morrow engineering department.
4. Foundation designed for minimum soil bearing of 1,000 psf.
5. Alternative pit foundation available. Contact Morrow for information.
6. Refer to the manufacturer's manual before installing, operating, servicing, repairing, jumping or dismantling hoist.
7. For specific information including dimensions, forces or alternative configurations, contact Morrow engineering.
8. 3/4" x 17" Williams™ High Tensile Spin-Lock Anchor Bolt and nut assembly. (R1S06C14 Head assembly with ASTM A109/C1045 bolt and nut) or approved equivalent. Bolt by contractor. Install according to bolt manufacturer's requirements. Drill holes 1 3/4-in diameter allowing for 11" embedment. Bolt is also available through Morrow upon request. R1S-type anchor bolts not intended for use at extreme cold temperatures.
9. 1/2" x 3" x 3" sq. washer ASTM A36 steel plate by contractor. Washer also available from Morrow upon request. Drill hole = 13/16" dia. at centerline.
10. This datasheet contains information for "typical" FC 6800-12 HS installation. Contact Morrow for additional information.

FC 6800-12 Hi-Speed Single

Foundation Details

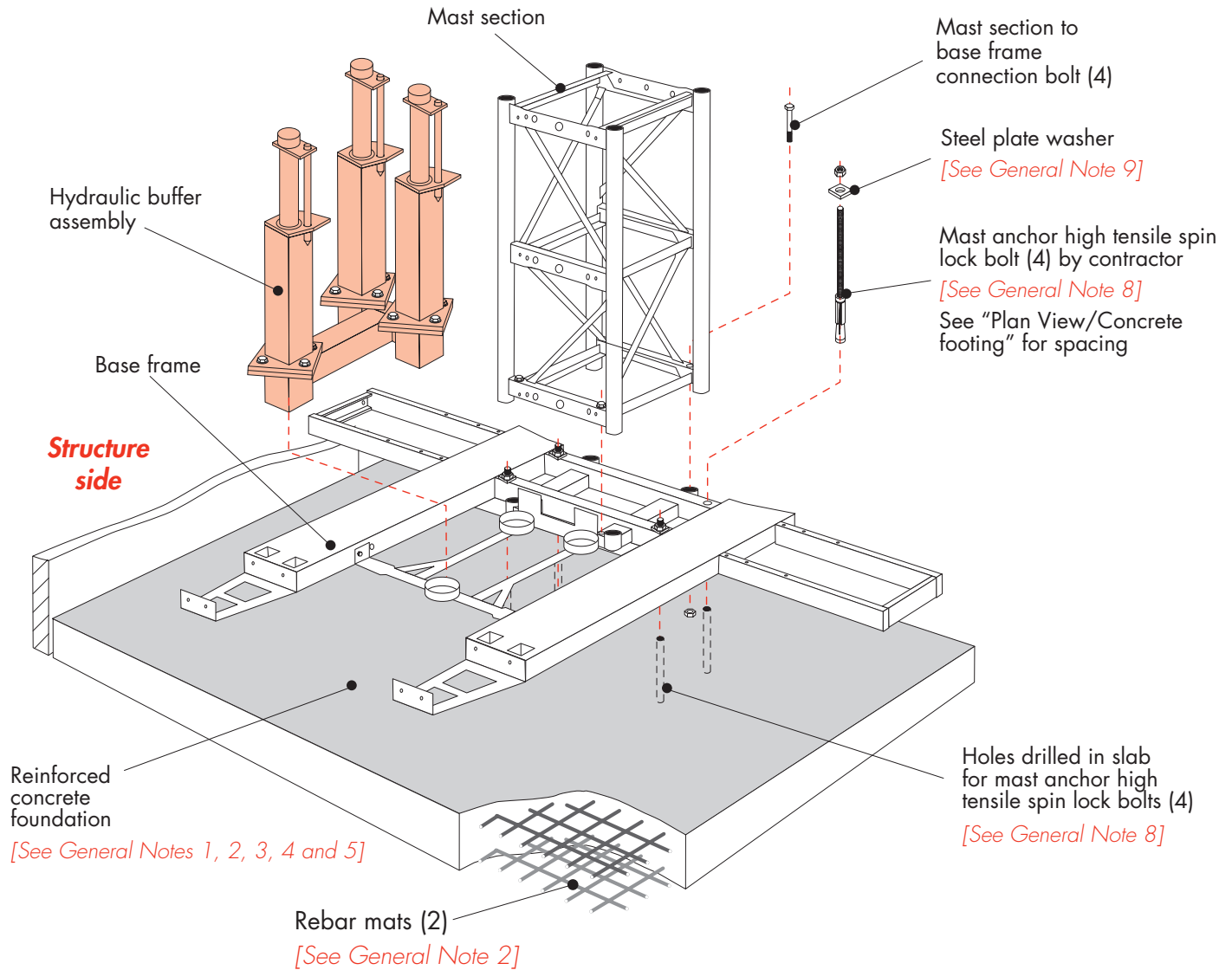

Foundation View Typical Single Car Installation

Note! Distance from building face to center of mast depends on the type of mast tie installed. Alternate anchoring methods available. Refer to Manual or contact Morrow Equipment for information.

Note! Hoist cars are equipped with doors at each end. An optional side door with a 10'-6" x 6'-7" opening is available.

FC 6800-12 Hi-Speed Single

Tie Details (S3A System) • slab mounted

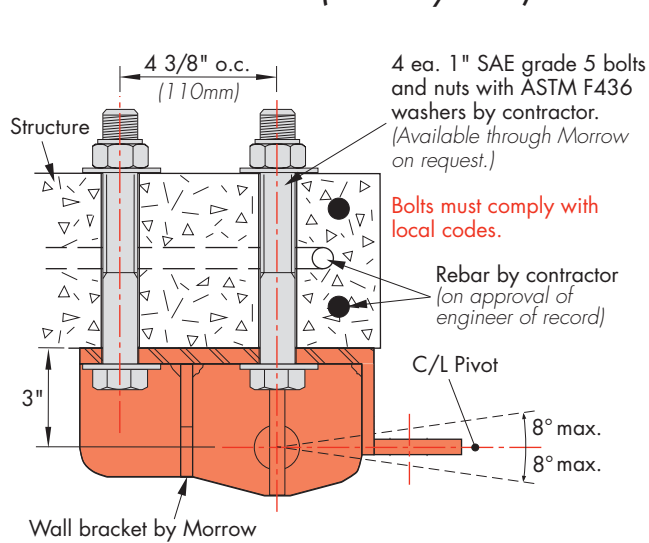

Mast Tie Connection

Slab mounted – Side view
Bottom attachment type

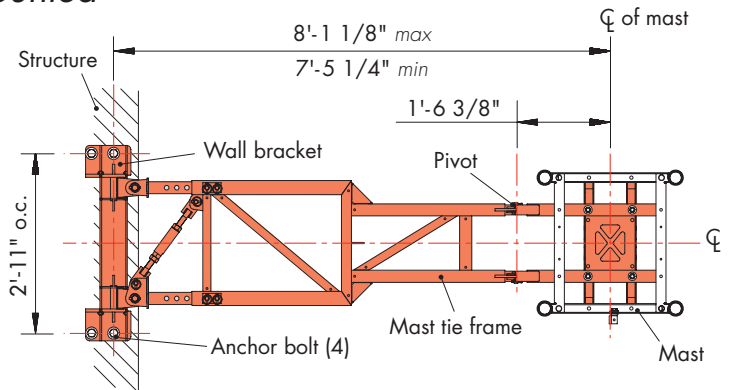

Mast Tie Assembly

Plan view

Note! Mast tie assemblies may be installed between $\pm 8^\circ$ from the horizontal.

Important! An additional 3" in mast tie length is added when using a wall-mounted tie connection.

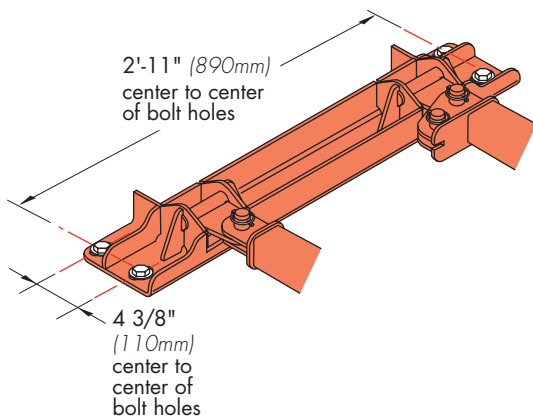

Slab Bracket

Typical – Isometric views

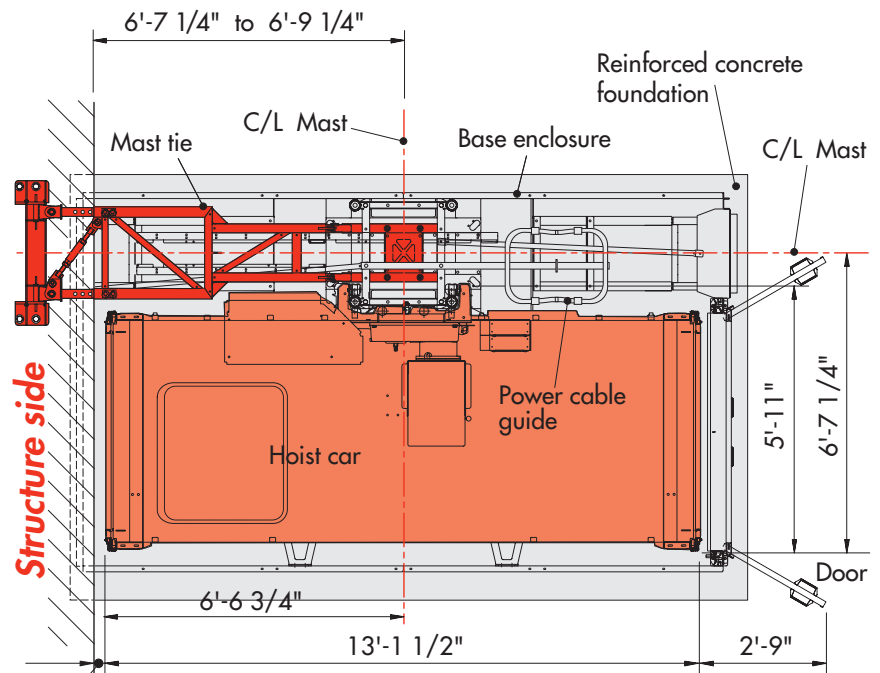

Plan View

IMPORTANT! ANSI A10.4 11.3 specifies a 1/2" (min.) to 2 1/2" (max.) clearance between car platform sill and landing sill. Verify before installing to assure compliance with applicable standards, codes and regulations.

FC 6800-12 Hi-Speed Single

Tie Details (S3A System) • wall mounted

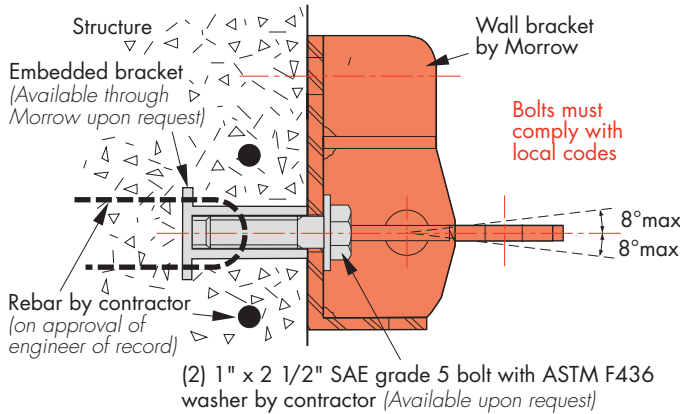

Mast Tie Connection

Face mounted – Side view
Wall attachment type

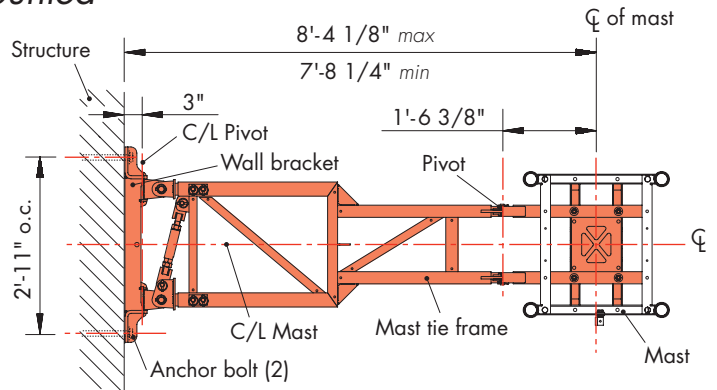

Mast Tie Assembly Plan view

Note! Mast tie assemblies may be installed between $\pm 8^\circ$ from the horizontal.

Important! A reduction of 3" in mast tie length is made when using a slab-mounted tie connection.

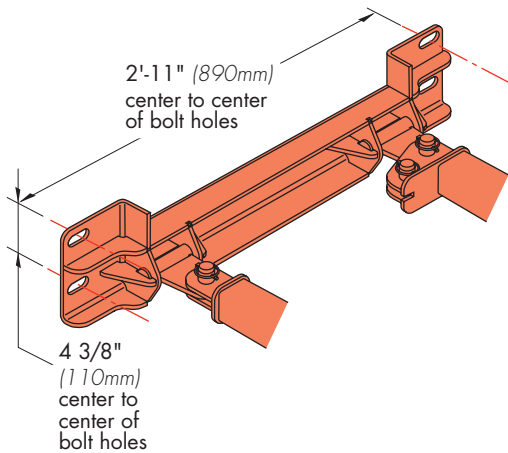

Wall Bracket Typical – Isometric views

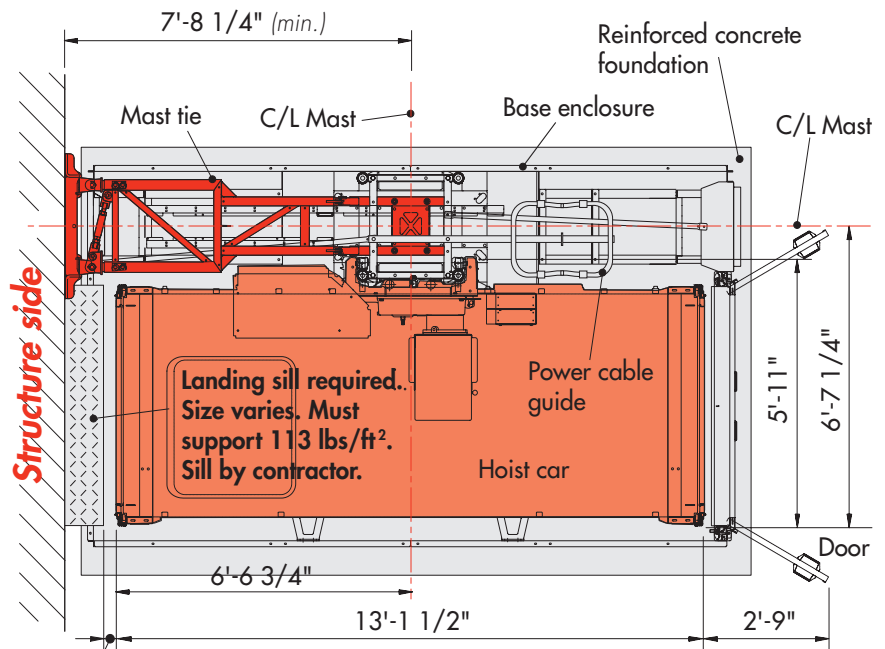

Plan View

IMPORTANT! ANSI A10.4 11.3 specifies a 1/2" (min.) to 2 1/2" (max.) clearance between car platform sill and landing sill. Verify before installing to assure compliance with applicable standards, codes and regulations.

FC 6800-12 Hi-Speed Single

Tie-in Details

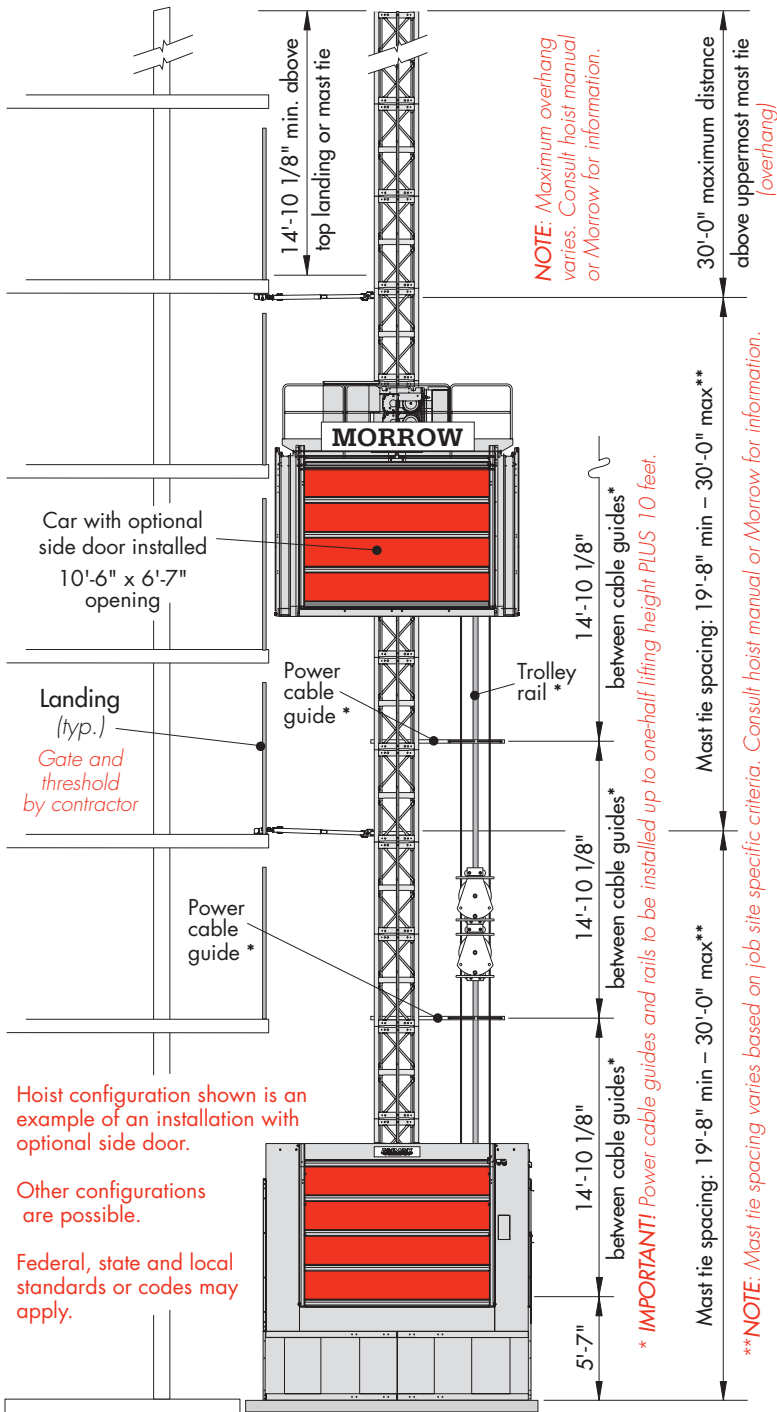

Hoist configuration shown is an example of an installation with optional side door.

Other configurations are possible.

Federal, state and local standards or codes may apply.

NOTE: Engineer of record to verify that slab/wall is adequate for anchor forces.
Maximum mast tie spacing is based on ANSI A10.4.

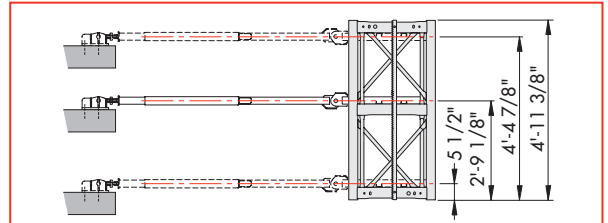

Mast S3A Tie
Attachment points/types

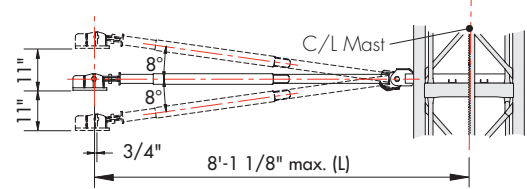

Inclination details

Mast tie lengths are from 7'-5 1/4" minimum to 8'-1 1/8" maximum when angle of inclination is 0° (horizontal). Mast tie inclination 0° to ±8°. Angles greater than 8° will cause interference with tie-in and car. Tie length adjustments are in 2" (50mm) increments. An additional 3" is gained in length (L) for wall mounting.

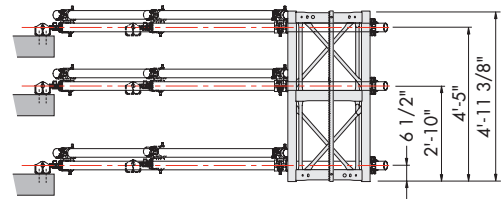

Mast S1A Tie
Attachment points/types

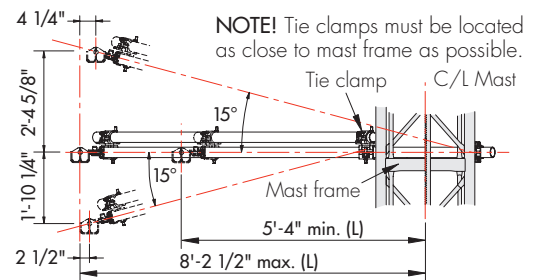

Inclination details

Mast tie lengths are from 5'-4" minimum to 8'-2 1/2" maximum when angle of inclination is 0° (horizontal). Mast tie inclination 0° to ±15°. An additional 3" is gained in length (L) for wall mounting.

FC 6800-12 Hi-Speed Single

Tie Details (S1A System)

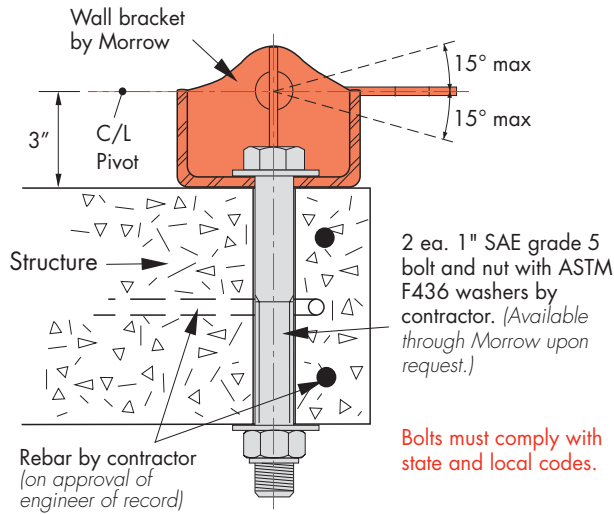

S1A Tie-in Bracket
Typical – Slab mount position

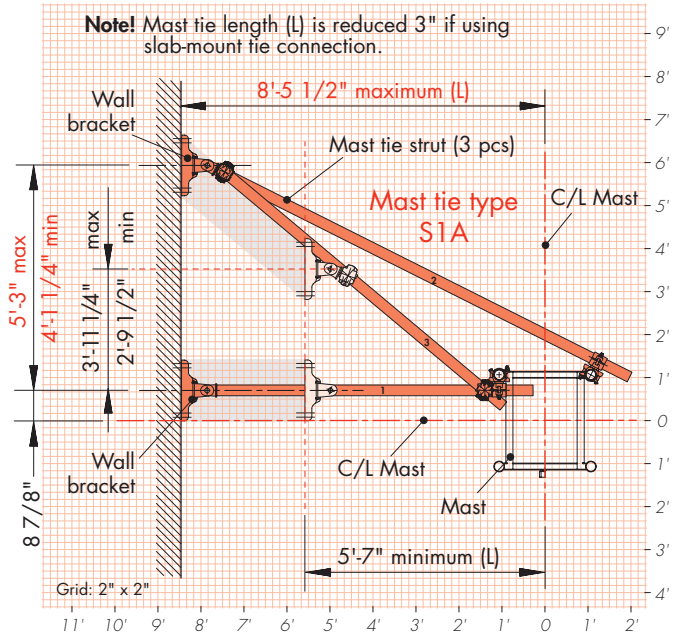

S1A Mast Tie Assembly
Plan view

[See General Note 7]

Note! S1A system mast tie assemblies may be installed between $\pm 15^\circ$ from the horizontal.

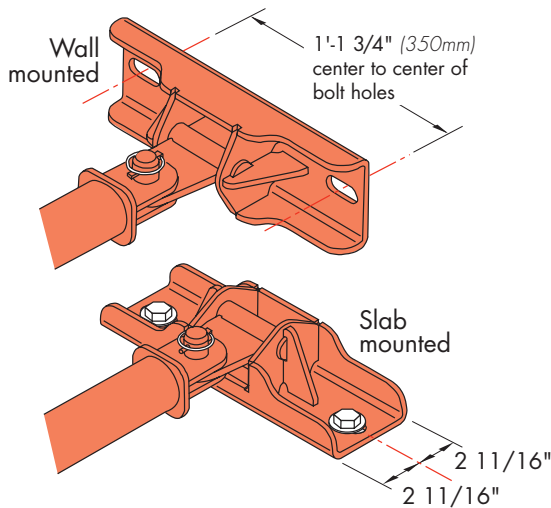

S1A Mast Tie Connection

IMPORTANT! ANSI A10.4 11.3 specifies a 1/2" (min.) to 2 1/2" (max.) clearance between car platform sill and landing sill. Verify before installing to assure compliance with applicable standards, codes and regulations.

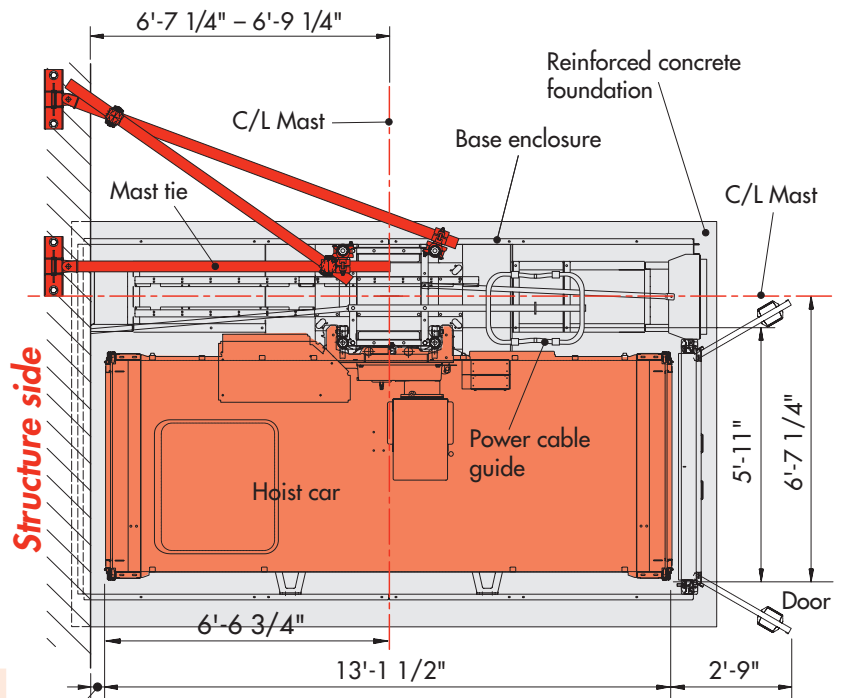

Plan View
Slab-mounted mast tie

SPECIFICATIONS

Alimak® FC 6800-12 HS Hi-Speed Single Car Construction Hoist

GENERAL

Max. load capacity	6,835 lbs	Max. height on standard masts	660'
Car inside dimensions (approx.)	12'-9" x 4'-11" x 7'-6 1/2"	Max. freestanding mast height ²	30'-0"
Door opening	6'-6 3/4" x 4'-10 3/4"	Maximum mast overhang ³	30'-0"
Mast section length.....	4'-11 3/8"	Maximum mast tie spacing ³	30'-0"
Speed	0 - 328 fpm	Minimum mast tie spacing	19'-8"
Motors (VFD)	3 x 30 hp	Power supply fuses	200 Amps
Power requirement ¹	480 Volt - 3 phase - 60 Hz	Starting current	185 Amps
		Power consumption	115 kVA

¹ 480 V phase-phase, 277 V each phase to ground with 120° phase shift between phases. 3-phase, 60 Hz power supply plus ground wire. Do not use Open-Delta supply.

² Requires use of an embedded foundation frame in lieu of mast anchor expansion bolts. See operation manual or contact Morrow engineering for specific information.

³ Overhang and mast tie spacing figures vary. See operation manual or contact Morrow engineering for specific information.

WEIGHTS

Base enclosure (without car or motor).....	2,340 lbs	Hoist car (without motorpack).....	3,610 lbs ea.
Base enclosure (with car & motor).....	8,600 lbs	Mast section (single rack)	254 lbs ea.
Motorpack (3 x 30 hp) (with panel).....	2,650 lbs	Mast section (double rack).....	298 lbs ea.

SAFETY FEATURES

- Electronic and mechanical door interlocks on hoist car and base enclosure doors.
- Automatic stop and final limit switches limit hoist car travel when reaching end positions.
- Main "ON/OFF" switch lockable to prevent unauthorized operation.
- Hydraulic buffers.
- NO counterweights required.

KEY FEATURES

- Hi-speed capability provides increased productivity delivering personnel and material more quickly.
- Equipped with highly efficient variable frequency drives for smooth, economical and dependable operation.
- Mast sections can be added without special equipment.
- Modular design facilitates ease of transport, erection and dismantlement.
- Recessed stainless steel control panel.
- ALC-II collective control system internal fault diagnostics system.
- A3 remote diagnostics system offers advantage of continuous and prompt service support.

IMPORTANT! Refer to manufacturer's manual before installing, operating, servicing, repairing, jumping or dismantling hoist. This datasheet contains general information for a "typical" FC 6800-12 HS (650 FC-S 31/39) Hi-Speed single car installation. For dimensions, reaction forces, mast tie locations, alternate configurations and special applications, contact Morrow Equipment.

Specifications and equipment shown are subject to modification without prior notification. This product and its components must be used in a safe manner, in conformity with manufacturer's specifications and in compliance with all applicable standards, codes, regulations, etc.



Morrow Equipment
C O M P A N Y, L. L. C.

3218 Pringle Road SE • P O Box 3306 • Salem, Oregon 97302-0306 USA
503.585.5721 • Fax 503.363.1172 • www.morrow.com • info@morrow.com

The American home of
LIEBHERR
TOWER CRANES

Atlanta, GA • Charlotte, NC • Chicago, IL • Denver, CO • Honolulu, HI • Houston, TX • Los Angeles, CA • Millwood, NY • Milwaukee, WI
Pensacola, FL • St. Louis, MO • San Francisco, CA • Dallas, TX • Seattle, WA • Miami, FL • Tampa, FL • Washington, DC
Sydney, Australia • Brisbane, Australia • Auckland, New Zealand • Wellington, New Zealand • Vancouver, BC, Canada • Toronto, ON, Canada • Mexico City, Mexico