

LIEBHERR 63 LC

GRÚA TORRE / Tower Crane

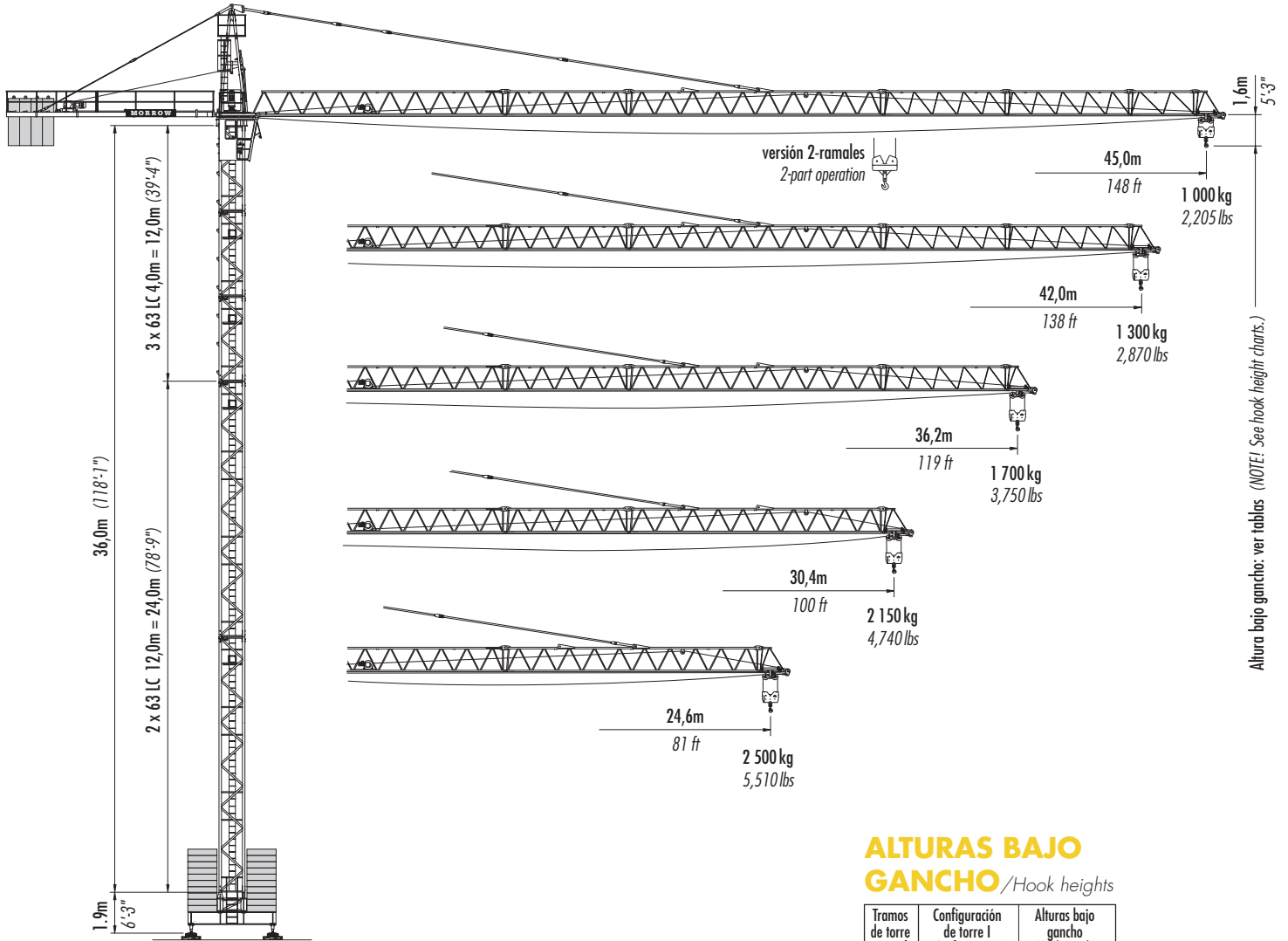

Configuración I
 Versión estacionaria
 (stationary)
 sobre husillos regulables
 altura máxima bajo gancho
 (maximum height under hook)
 36,9m (121'-1")

ESTACIONARIA
 Freestanding - Stationary

ALTURAS BAJO GANCHO / Hook heights

Tramos de torre No. of sections	Configuración de torre I Configuration I	Alturas bajo gancho Hook Height	
		m	ft
1	63 LC - 12m	12,9	42.3
2	63 LC - 12m	24,9	81.7
3	63 LC - 4m	28,9	94.8
4	63 LC - 4m	32,9	107.9
5	63 LC - 4m	36,9	121.1

Otras configuraciones de torre son posibles. Consultar con Morrow.
 Other tower combinations are possible.
 Contact Morrow for additional information.



Morrow Maquinarias

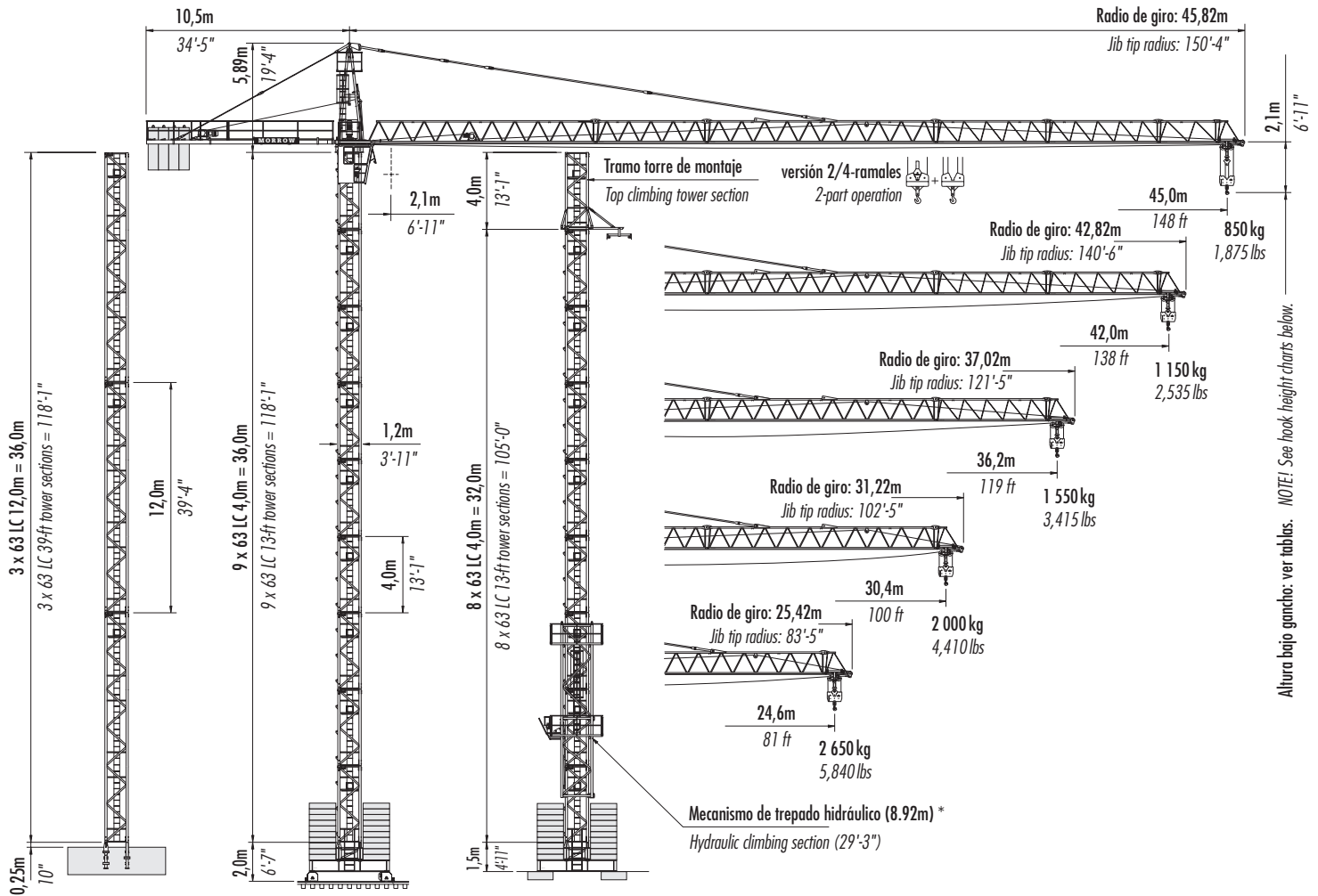

Altura bajo gancho: ver tablas. NOTE: See hook height charts below.

Configuración II
Versión estacionaria
(stationary)
sobre pies de anclaje
altura máxima
bajo gancho
(maximum height
under hook)
35,3m (115'-10")

Configuración III
Versión móvil
(rail travelling)
sobre railes
altura máxima
bajo gancho
(maximum height
under hook)
37,0m (121'-5")

Configuración IV
Versión estacionaria
(stationary)
sobre fundaciones de hormigón
altura máxima
bajo gancho
(maximum height
under hook)
36,5m (119'-9")

* El mecanismo de trepado hidráulico debe bajarse después del montaje.
Lower top climbing unit to base prior to operating crane.

Consultar el manual de instrucciones «Grúa torre 63 LC» antes del montaje, manejo y desmontaje de la grúa.

Otras configuraciones de torre son posibles. Consultar con Morrow.

Other tower combinations are possible. Contact Morrow for additional information.

Please consult crane's operation manual before erecting, operating and dismantling crane.

Configuraciones

LIEBHERR 63 LC

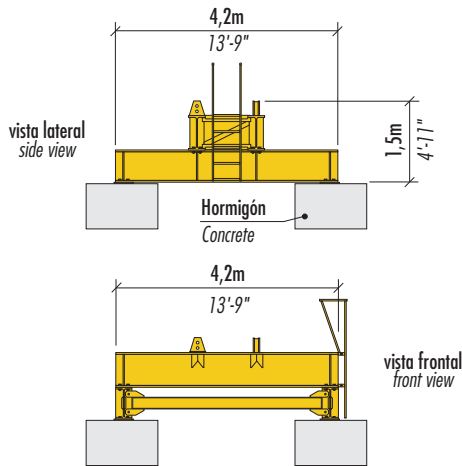

VISTAS del CARRETÓN

versión estacionaria sobre fundaciones de hormigón
(Views of base on concrete footings)

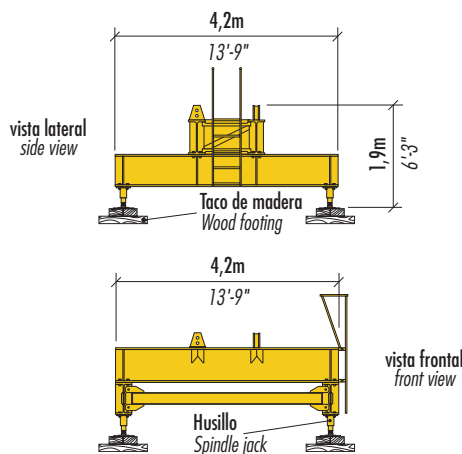

VISTAS del CARRETÓN

versión estacionaria sobre husillos regulables
(Views of base on adjustable spindle jacks)

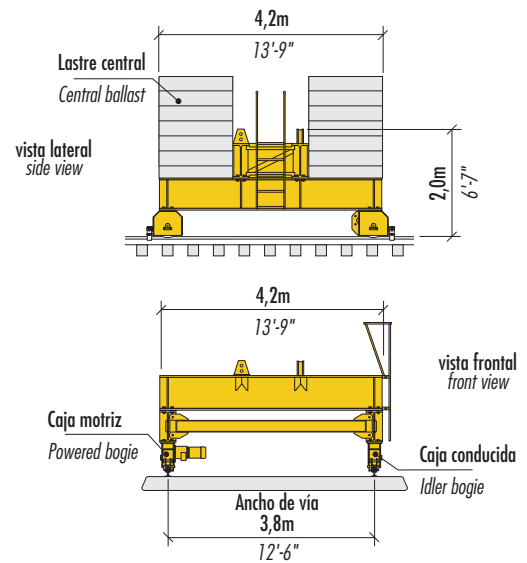

VISTAS del CARRETÓN

versión móvil sobre railes
(Views of rail travelling base)

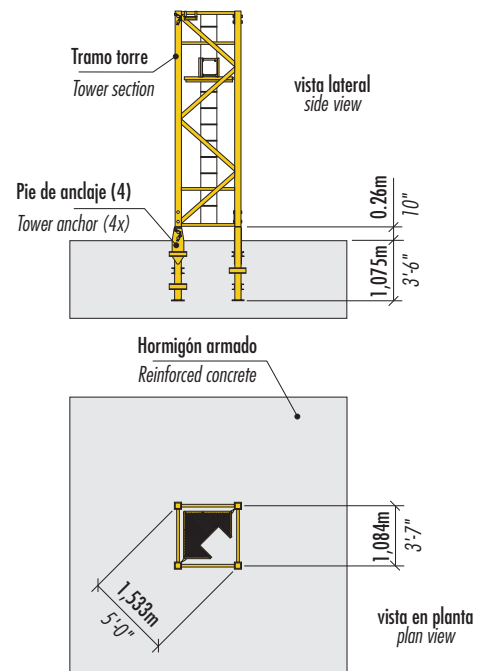

VISTAS de la ZAPATA de CIMENTACION







con tramos de torre «63 LC»
sobre pies de anclaje
(Views of concrete foundation)

ALTURAS BAJO GANCHO / Hook heights







Tramos de torre No. of sections	Configuración de torre II Configuration II	Alturas bajo gancho Hook Height		Tramos de torre No. of sections	Configuración de torre III Configuration III	Alturas bajo gancho Hook Height		Tramos de torre No. of sections	Configuración de torre IV Configuration IV	Alturas bajo gancho Hook Height	
		m	ft			m	ft			m	ft
1	63 LC 12m	11,3	37.1	1	63 LC 4m	5,0	16.4	1	63 LC 4m	4,5	14.8
2	63 LC 12m	23,3	76.4	2	63 LC 4m	9,0	29.5	2	63 LC 4m	8,5	27.9
3	63 LC 12m	35,3	115.8	3	63 LC 4m	13,0	42.7	3	63 LC 4m	12,5	41.0
				4	63 LC 4m	17,0	55.8	4	63 LC 4m	16,5	54.1
				5	63 LC 4m	21,0	68.9	5	63 LC 4m	20,5	67.3
				6	63 LC 4m	25,0	82.0	6	63 LC 4m	24,5	80.4
				7	63 LC 4m	29,0	95.1	7	63 LC 4m	28,5	93.5
				8	63 LC 4m	33,0	108.3	8	63 LC 4m	32,5	106.6
				9	63 LC 4m	37,0	121.4	9*	63 LC 4m	36,5	119.8

*El mecanismo de trepado hidráulico debe bajarse después del montaje.
Lower top climbing unit to base prior to operating crane.

2-ramales (2-part line)

Pluma Jib	Carga máxima Maximum capacity		m ft	2,1 7	12,0 39	14,0 46	16,0 53	18,0 59	20,0 66	22,0 72	24,6 81	28,0 92	30,4 100	34,0 112	36,2 119	40,0 131	42,0 138	45,0 148
45,0m 148 ft	2 500 kg – 20,6m 5,510 lbs – 67.6 ft		kg lbs	2 500 5,510	2 500 5,510	2 500 5,510	2 500 5,510	2 500 5,510	2 500 5,510	2 330 5,135	2 050 4,520	1 770 3,900	1 610 3,550	1 410 3,110	1 310 2,890	1 160 2,555	1 090 2,400	1 000 2,205
42,0m 138 ft	2 500 kg – 23,8m 5,510 lbs – 78.1 ft		kg lbs	2 500 5,510	2 500 5,510	2 500 5,510	2 500 5,510	2 500 5,510	2 500 5,510	2 500 5,510	2 410 5,315	2 080 4,585	1 900 4,190	1 670 3,680	1 550 3,415	1 380 3,040	1 300 2,870	
36,2m 119 ft	2 500 kg – 25,7m 5,510 lbs – 84.3 ft		kg lbs	2 500 5,510	2 500 5,510	2 500 5,510	2 500 5,510	2 500 5,510	2 500 5,510	2 500 5,510	2 500 5,510	2 280 5,025	2 080 4,585	1 830 4,035	1 700 3,750			
30,4m 100 ft	2 500 kg – 26,6m 5,510 lbs – 87.3 ft		kg lbs	2 500 5,510	2 500 5,510	2 500 5,510	2 500 5,510	2 500 5,510	2 500 5,510	2 500 5,510	2 500 5,510	2 360 5,205	2 150 4,740					
24,6m 81 ft	2 500 kg – 24,6m 5,510 lbs – 81.0 ft		kg lbs	2 500 5,510	2 500 5,510	2 500 5,510	2 500 5,510	2 500 5,510	2 500 5,510	2 500 5,510	2 500 5,510							

2/4-ramales (2/4-part line)

Pluma Jib	Carga máxima Maximum capacity		m ft	2,1 7	12,0 39	14,0 46	16,0 53	18,0 59	20,0 66	22,0 72	24,6 81	28,0 92	30,4 100	34,0 112	36,2 119	40,0 131	42,0 138	45,0 148
45,0m 148 ft	2 500 kg – 19,8m 5,510 lbs – 65.0 ft		kg lbs	5 000 11,025	4 480 9,875	3 760 8,290	3 220 7,100	2 800 6,175	2 470 5,445	2 200 4,850	1 920 4,235	1 630 3,595	1 470 3,240	1 260 2,775	1 160 2,560	1 010 2,225	940 2,075	850 1,875
42,0m 138 ft	2 500 kg – 22,8m 5,510 lbs – 74.8 ft		kg lbs	5 000 11,025	5 000 11,025	4 400 9,700	3 780 8,335	3 300 7,275	2 920 6,440	2 610 5,755	2 280 5,025	1 950 4,300	1 760 3,880	1 520 3,350	1 400 3,085	1 230 2,710	1 150 2,535	
36,2m 119 ft	2 500 kg – 24,5m 5,510 lbs – 80.4 ft		kg lbs	5 000 11,025	5 000 11,025	4 790 10,560	4 110 9,060	3 600 7,935	3 180 7,010	2 850 6,285	2 500 5,510	2 140 4,720	1 930 4,255	1 680 3,705	1 550 3,415			
30,4m 100 ft	2 500 kg – 26,3m 5,510 lbs – 86.3 ft		kg lbs	5 000 11,025	5 000 11,025	4 940 10,890	4 250 9,370	3 710 8,180	3 290 7,255	2 940 6,480	2 580 5,690	2 210 4,870	2 000 4,410					
24,6m 81 ft	2 500 kg – 24,6m 5,510 lbs – 81.0 ft		kg lbs	5 000 11,025	5 000 11,025	5 000 11,025	4 360 9,610	3 810 8,400	3 370 7,430	3 020 6,660	2 650 5,840							

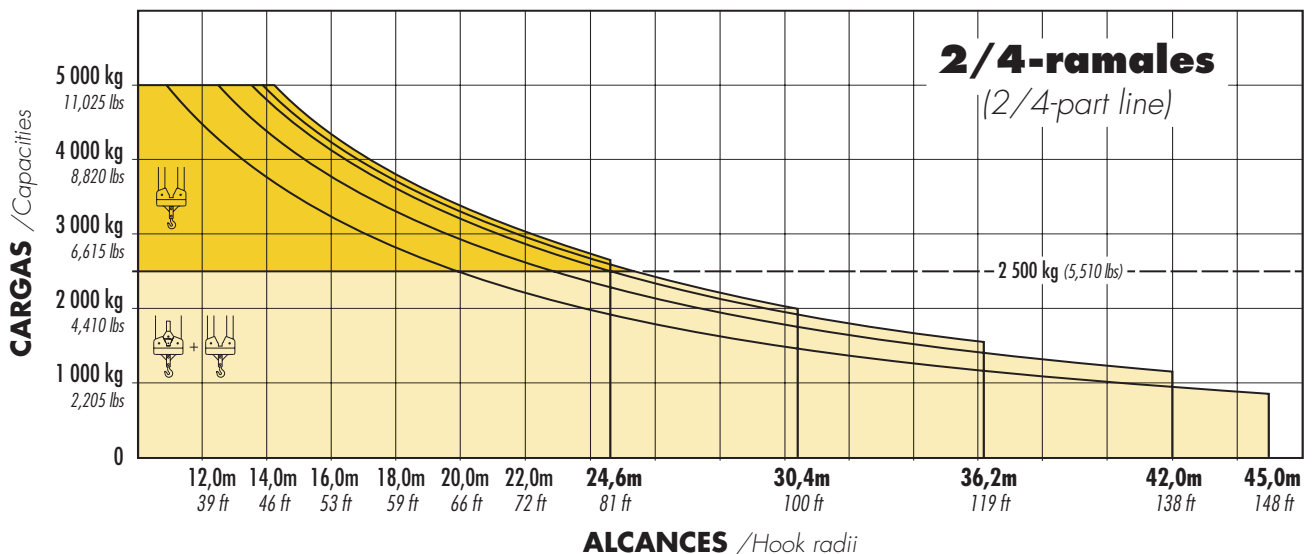

DATOS TECNICOS

LIEBHERR Grúa torre 63 LC

Velocidad de elevación y Carga máxima /Hoist unit data

Mecanismo elevación WiW 210 MY 300 14 kV mecanismo de elevación asincronico (19 hp AC hoist unit) • motor de rotor en corto-circuito de polos conmutables con 3 marchas (3-step pole-changing motor) • tambor de cable LS (Lebus-type LS drum) 2P119 4P59	2-ramales (2-part line)				
	marcha step	carga	velocidad	Capacity	Line Speed
	1	hasta 2 500 kg	8 m/min	up to 5,510 lbs	26 fpm
	2	hasta 2 500 kg	28 m/min	up to 5,510 lbs	92 fpm
	3	hasta 1 100 kg	56 m/min	up to 2,425 lbs	184 fpm
	4-ramales (4-part line)				
	1	hasta 5 000 kg	4 m/min	up to 11,025 lbs	13 fpm
	2	hasta 5 000 kg	14 m/min	up to 11,025 lbs	46 fpm
	3	hasta 2 400 kg	28 m/min	up to 5,290 lbs	92 fpm

¡NOTA! Las cargas máximas y velocidades de elevación indicadas variarán dependiendo de la cantidad de cable instalado en el tambor. Este modelo de grúa puede ser equipado con un mecanismo de elevación diferente al especificado en la tabla superior. Para verificar esto, consulte el número de serie de la grúa y el manual de instrucciones de la Liebherr 63 LC para más información.

NOTE! Capacities and line speeds indicated will vary depending on the amount of hoist rope installed. This crane model may be equipped with a hoist unit other than that specified in the data above. To verify, check the serial number of the crane and refer to the Liebherr 63 LC Operation Manual for additional information.

Motores /Drives

Motor (Drive unit)	Kilowatios	Horsepower	Velocidades (Speeds)	
Carrito – 2-ramales (2-part Trolley)	1,5/3,0 kW	2.0/4.0 hp	21,0/42,0 m/min	69/138 fpm
Carrito – 2/4-ramales (2/4-part Trolley)	1,5/3,0 kW	2.0/4.0 hp	21,0/42,0 m/min	69/138 fpm
Mecanismo de giro (Slewing)	3,0 kW	4.0 hp	0.8 rpm	
Traslación (Rail travelling)	2 x 2,2 kW	2 x 2.9 hp	20,0 m/min	66 fpm











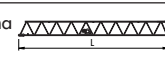
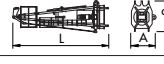

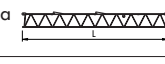
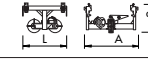

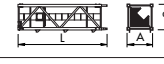
Potencia eléctrica requerida /Power requirements

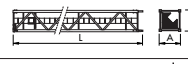
440 V — 3 fases — 60 Hz — 50 Amperios — 26 kVA

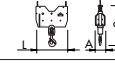
Esta información está sujeta a cambios sin previo aviso. Para más información, comuníquese con Morrow Maquinarias de México.
Subject to changes without prior notice. For additional information, contact Morrow.

Lista de componentes

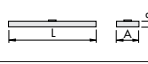
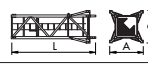
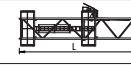
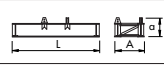
LIEBHERR 63 LC

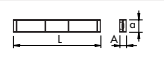
Componente	Dimensiones <i>Largo x Ancho x alto</i>	Peso	Componente	Dimensiones <i>Largo x Ancho x alto</i>	Peso
Cabina con butaca ¹ <i>Operator's cab</i>	 1,87m x 1,12m x 3,3m 6'-2" x 3'-8" x 10'-10"	600 kg 1,325 lbs	Tramo de pluma <i>Jib section</i> ① 	11,85m x 1,04m x 1,3m 38'-11" x 3'-5" x 4'-3"	1 070 kg 2,360 lbs
Cabeza de torre ² <i>Tower top</i>	 5,89m x 1,86m x 1,73m 19'-4" x 6'-1" x 5'-8"	2 740 kg 6,040 lbs	Tramo de pluma ② 	5,94m x 0,95m x 1,22m 19'-6" x 3'-1" x 4'-0"	401 kg 885 lbs
Contrapluma ³ <i>Counterjib</i>	 9,79m x 1,46m x 1,39m 32'-1" x 4'-9" x 4'-7"	1 570 kg 3,460 lbs	Tramo de pluma <i>Jib section</i> ③ 	11,8m x 0,95m x 1,32m 38'-5" x 3'-1" x 4'-4"	810 kg 1,785 lbs
Carrito <i>Trolley</i>	 0,95m x 1,13m x 0,62m 3'-1" x 3'-8" x 2'-0"	151 kg 335 lbs	Tramo de pluma ④ 	5,94m x 0,95m x 1,22m 19'-6" x 3'-1" x 4'-0"	261 kg 575 lbs
Tramo de torre ⁴ <i>Std. tower section</i>	 4,27m x 1,2m x 1,3m 14'-0" x 3'-11" x 4'-3"	958 kg 2,112 lbs	Tramo de pluma ⑤ 	5,94m x 0,95m x 1,22m 19'-6" x 3'-1" x 4'-0"	210 kg 465 lbs
Tramo de torre <i>Long tower section</i>	 12,27m x 1,2m x 1,2m 40'-3" x 3'-11" x 3'-11"	2 435 kg 5,370 lbs	Tramo de pluma ⑥ 	3,18m x 0,95m x 1,22m 10'-5" x 3'-1" x 4'-0"	111 kg 245 lbs
Gancho <i>Hook block</i>	 0,75m x 0,24m x 0,98m 2'-6" x 9" x 3'-3"	104 kg 230 lbs	Tramo de pluma ⑦ <i>Jib tip section</i> 	1,45m x 1,04m x 1,37m 4'-9" x 3'-5" x 4'-6"	80 kg 175 lbs
Mecanismo de elevación ⁵ <i>Hoist unit</i>	 1,25 x 1,23m x 0,55m 4'-1" x 4'-0" x 1'-10"	450 kg 990 lbs	Pluma (45,0m) ⁷ <i>Jib assembly (148 ft)</i> ①②③④⑤⑥⑦	45,82m x 1,04m x 1,37m 150'-4" x 3'-5" x 4'-6"	3 660 kg 8,070 lbs
Contrapeso/bloque A <i>Counterweight A</i>	 0,81m x 0,52m x 2,4m 2'-8" x 1'-8" x 7'-10"	2 250 kg 4,960 lbs	Pluma (42,0m) ⁷ <i>Jib assembly (138 ft)</i> ①②③④⑤⑦	42,82m x 1,04m x 1,37m 140'-6" x 3'-5" x 4'-6"	3 540 kg 7,805 lbs
Contrapeso/bloque B <i>Counterweight B</i>	 0,81m x 0,52m x 1,38m 2'-8" x 1'-8" x 4'-6"	1 200 kg 2,645 lbs	Pluma (36,2m) ⁷ <i>Jib assembly (119 ft)</i> ①②③④⑦	37,02m x 1,04m x 1,37m 121'-5" x 3'-5" x 4'-6"	3 260 kg 7,190 lbs
Lastre central/bloque <i>Central ballast</i>	 4,0m x 1,2m x 0,22m 13'-1" x 3'-11" x 9"	2 500 kg 5,510 lbs	Pluma (30,4m) ⁷ <i>Jib assembly (100 ft)</i> ①②③⑦	31,22m x 1,04m x 1,37m 102'-5" x 3'-5" x 4'-6"	2 990 kg 6,590 lbs
Tramo torre de montaje <i>Climber tower section</i>	 4,27m x 1,66m x 1,66m 14'-0" x 5'-5" x 5'-5"	1 120 kg 2,470 lbs	Pluma (24,6m) ⁷ <i>Jib assembly (81 ft)</i> ①③⑦	25,42m x 1,04m x 1,37m 83'-5" x 3'-5" x 4'-6"	2 520 kg 5,555 lbs
Mecanismo de trepado ⁶ <i>Top climbing unit</i>	 8,92m x 2,8m x 3,3m 29'-3" x 9'-2" x 10'-10"	2 900 kg 6,395 lbs	Bastidor carrerón <i>Undercarriage frame</i> 	4,12m x 0,94m x 1,39m 13'-6" x 3'-1" x 4'-7"	2 575 kg 5,680 lbs
Accesorios y cables <i>Accessories and Rope</i>	 — —	1 300 kg 2,865 lbs	Brazo (2) <i>Outrigger (ea.)</i> 	4,1m x 0,3m x 0,6m 13'-5" x 1'-0" x 2'-0"	935 kg 2,060 lbs

AVISO: Verifiquen los pesos y dimensiones de los componentes antes de ser instalados. *Weights & dimensions are approximate. Verify weights & dimensions of components before lifting.*

- Incluye cabina, butaca y plataforma con barandillas. *Cab assembly includes operator's cab, operator's desk and access platform with handrails.*
- Incluye cabeza de torre, mecanismo de giro, armario eléctrico, tirantes, pista de giro y asiento pista. *Tower top unit includes tower top, electrical panel (S1), pendants, swing motor, slewing ring and slewing ring support.*
- Incluye contrapluma con tirantes y barandillas, mecanismo de elevación sin cable. *Includes counterjib section, hoist unit, pendants & handrails. Does not include wire rope.*
- Con apoyos de trepado. *With climbing lugs.*
- 14,0 kW mecanismo de elevación asincrónico (C.A.) sin cable. *19 hp AC hoist unit. Does not include wire rope.*
- Mecanismo de trepado hidráulico incluye plataformas con barandillas, grupo hidráulico, escalera, brazos soporte y bastidor. *Top climbing unit consists of tower frame with platforms and handrails, hydraulic unit with ram and support shoes, and access ladder.*
- Incluye tramos de pluma, mecanismo de traslación del carrito, carrito, cables de traslación carrito, tirantes de suspensión de la pluma y pernos de conexión. *Jib assemblies consist of jib sections, trolley, trolley drive unit with wire rope, pendant bars and connecting pins.*

El hogar americano de
LIEBHERR

Morrow Equipment

COMPANY, L. L. C.
3218 Pringle Road SE • P O Box 3306
Salem, Oregon 97302-0306 USA
Tel. 503.585.5721 • Fax. 503.363.1172
www.morrowequipment.com

Morrow Maquinarias

de México, S.R.L. de C.V.
Santa Teresa n.º 64 – Despacho 101 • Colonia Tepalcates
CP 09210 • México DF, México • Tel. 5 452 0775
[Houston, TX: Tel. 713 733 9461 • Fax. 713 731 9405]

Atlanta, GA • Charlotte, NC • Chicago, IL • Denver, CO • Honolulu, HI • Houston, TX • Los Angeles, CA • Las Vegas, NV
Millwood, NY • St. Louis, MO • San Francisco, CA • Seattle, WA • Miami, FL • Tampa, FL • Washington, DC
Sydney, Australia • Wellington, New Zealand • Vancouver, BC, Canada • Toronto, ON, Canada • México DF, México