

LIEBHERR 301 C

TOWER CRANE

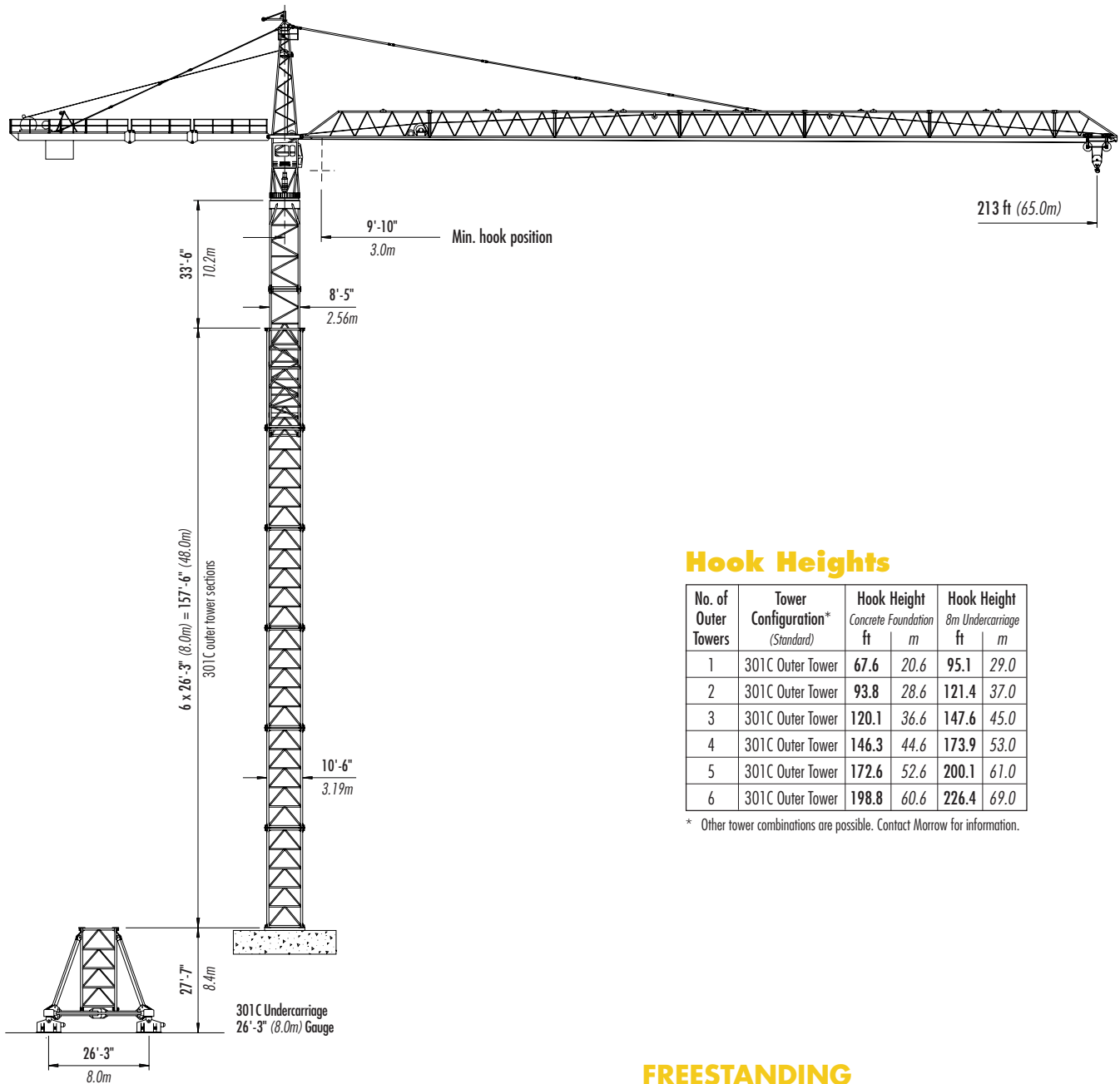

Hook Heights

No. of Outer Towers	Tower Configuration* (Standard)	Hook Height		Hook Height	
		Concrete Foundation	8m Undercarriage	ft	m
1	301C Outer Tower	67.6	20.6	95.1	29.0
2	301C Outer Tower	93.8	28.6	121.4	37.0
3	301C Outer Tower	120.1	36.6	147.6	45.0
4	301C Outer Tower	146.3	44.6	173.9	53.0
5	301C Outer Tower	172.6	52.6	200.1	61.0
6	301C Outer Tower	198.8	60.6	226.4	69.0

* Other tower combinations are possible. Contact Morrow for information.

Standard Configuration

with 301C Tower

max. 199 ft (60.6m) HUH on concrete foundation

max. 226 ft (69.0m) HUH on undercarriage

FREESTANDING Stationary & Travelling



Morrow Equipment

Configurations

LIEBHERR 301 C

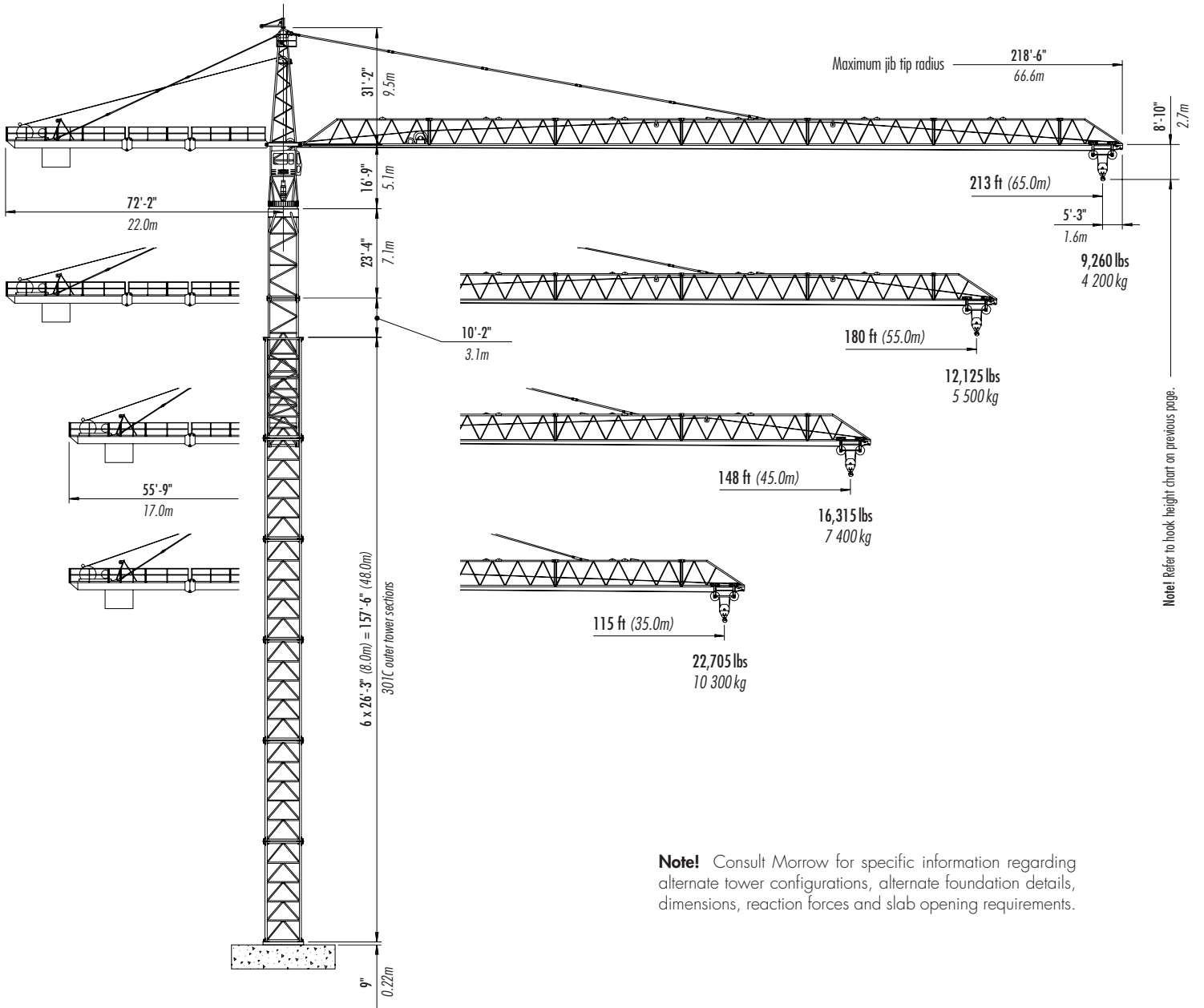

Note: Refer to hook height chart on previous page.

Note! Consult Morrow for specific information regarding alternate tower configurations, alternate foundation details, dimensions, reaction forces and slab opening requirements.

**STATIONARY
FREESTANDING**
with 301C Tower Sections

Configurations

LIEBHERR 301 C

Note! If hook height exceeds 330 ft (100m), the number of tower sections above the uppermost tie-in location **MUST** be reduced by one tower section.

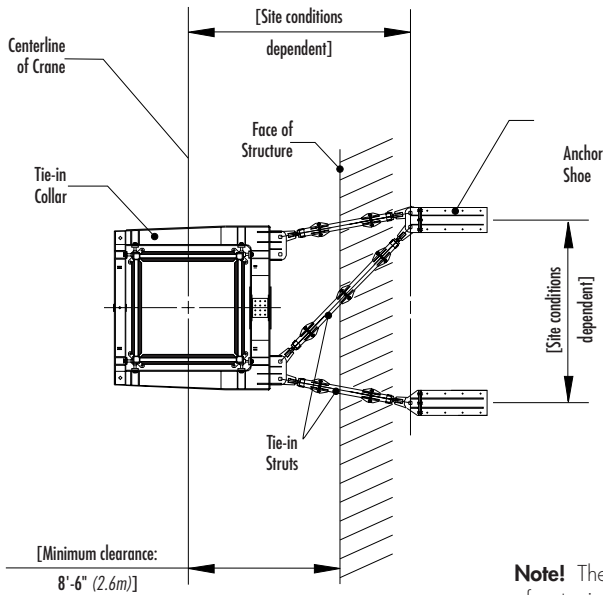

TIE-IN ASSEMBLY
(Plan View)

Note! The tie-in assembly shown is an example of a typical installation. Please note, however, that factors determining the installation of tie-in assemblies may vary due to project specific criteria. Contact Morrow for information regarding dimensions, reaction forces, tie-in locations, foundation details and slab opening requirements.

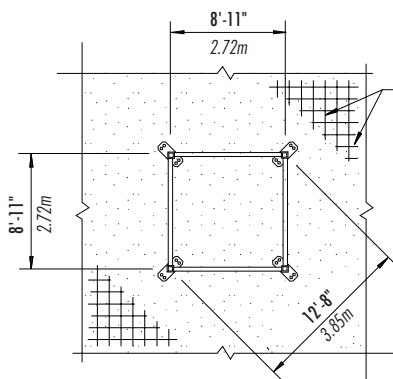

Plan View

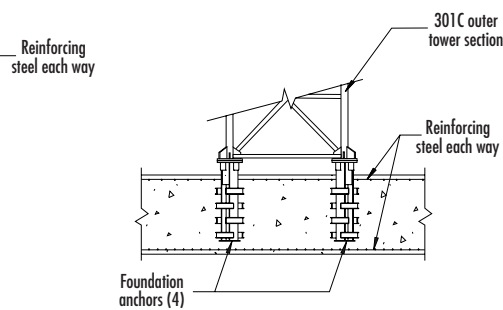

Elevation

FOUNDATION DETAILS
with 301C Tower Sections
(Concrete Slab)

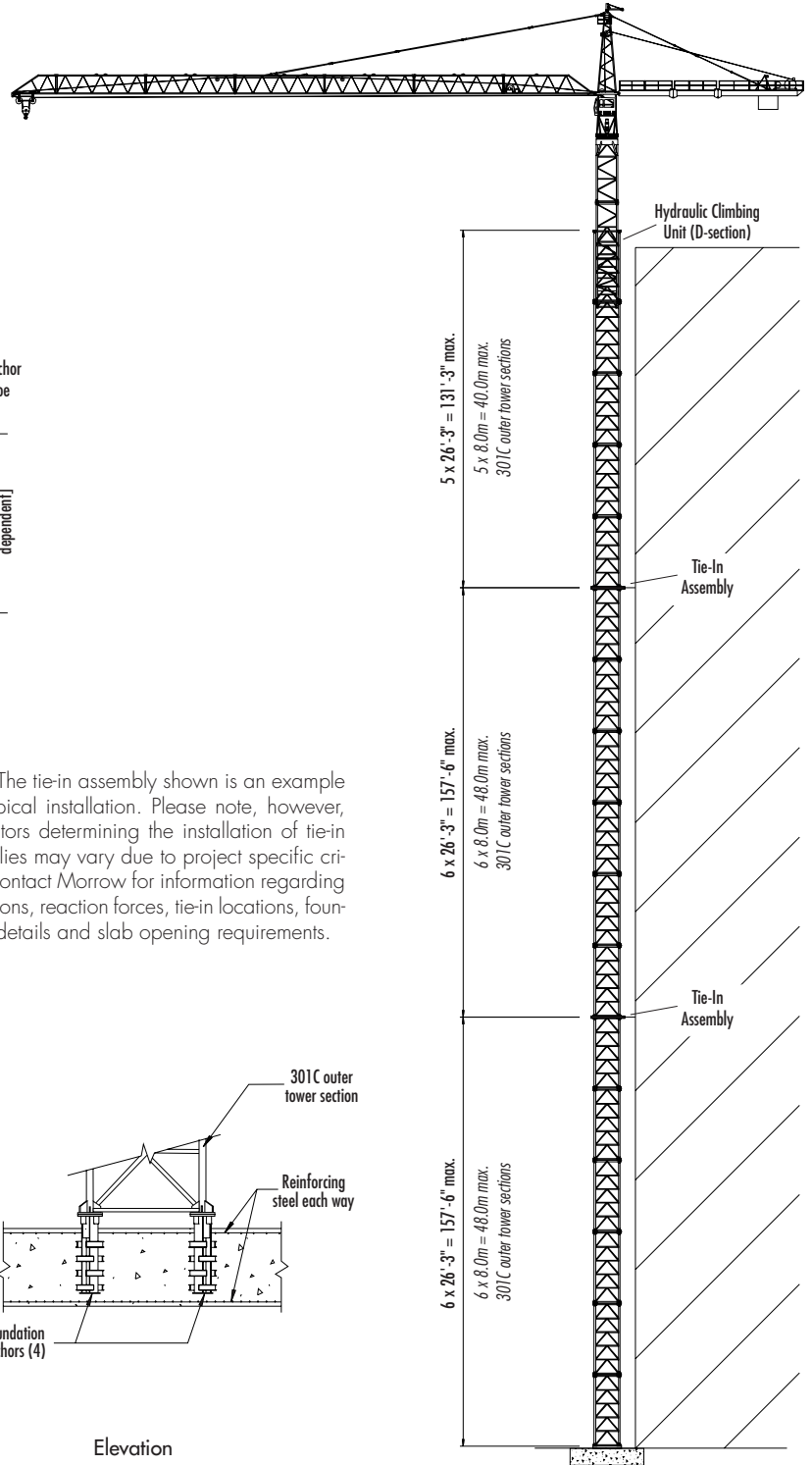

TOP CLIMBING
with 301C Tower Sections
(Tied to Structure)

Radius and Capacities

LIEBHERR Tower Crane Model 301 C

2-Part Line

Hook Radius	2-Part Line Max Capacity – Radius	ft m	45	55	65	75	85	95	105	115	130	140	148	160	170	180	190	200	213	
			13.7	16.8	19.8	22.9	25.9	29.0	32.0	35.0	39.6	42.7	45.0	48.8	51.8	55.0	57.9	61.0	65.0	
213 ft 65.0m	35,275 lbs – 73 ft 16 000 kg – 22.3m	lbs kg	35,275 16 000	35,275 16 000	35,275 16 000	34,000 15 420	29,000 13 155	25,500 11 565	22,500 10 205	20,100 9 115	17,300 7 845	15,600 7 075	14,700 6 670	13,300 6 035	12,400 5 625	11,400 5 170	10,750 4 875	10,000 4 535	9,260 4 200	
180 ft 55.0m	44,090 lbs – 64 ft 20 000 kg – 19.5m	lbs kg	44,090 20 000	44,090 20 000	42,500 19 280	35,200 15 965	30,050 13 630	26,450 12 000	23,450 10 635	21,050 9 550	18,000 8 165	16,550 7 505	15,400 6 985	14,000 6 350	13,000 5 895	12,125 5 500				
148 ft 45.0m	44,090 lbs – 65 ft 20 000 kg – 19.8m	lbs kg	44,090 20 000	44,090 20 000	44,090 20 000	36,400 16 510	31,250 14 175	27,550 12 495	24,400 11 070	22,050 10 000	19,000 8 620	17,450 7 915	16,315 7 400							
115 ft 35.0m	44,090 lbs – 66 ft 20 000 kg – 20.1m	lbs kg	44,090 20 000	44,090 20 000	44,090 20 000	37,500 17 010	32,150 14 585	28,000 12 700	25,000 11 340	22,705 10 300										

Capacity

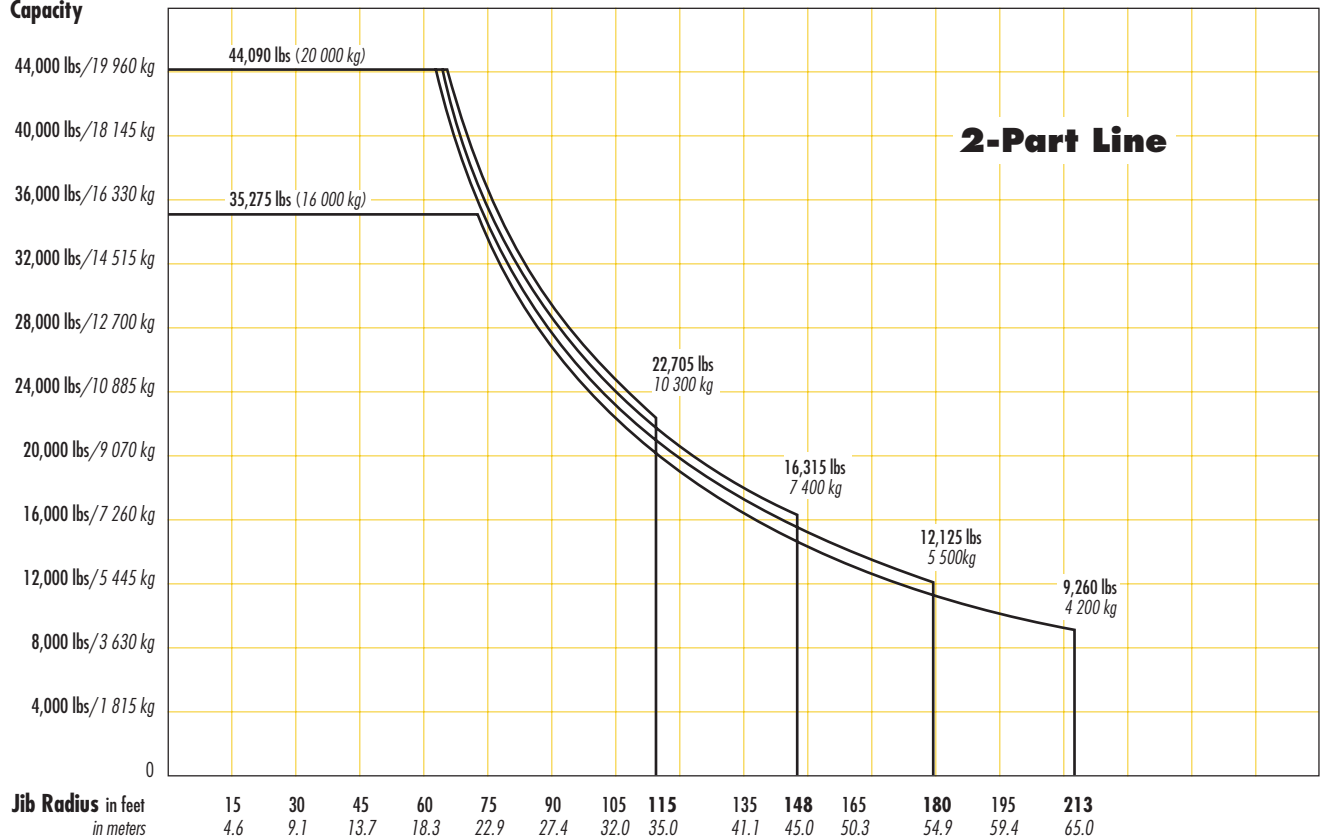

SPECIFICATIONS

LIEBHERR Tower Crane Model 301 C

IMPORTANT: This data applies only to crane with serial number #1304

Hoist Speed and Capacity

Hoist Unit	WiW 301 RX 005	2-Part Line (Standard)				
147 hp (110 kW) DC hoist unit Ward Leonard 4-speed gearbox Electromagnetic gear shifting LS226		Gear	Capacity	Line Speed	Capacity	Line Speed
		1	44,090 lbs	@ 90 fpm	20 000 kg	@ 27 m/min
		2	26,455 lbs	@ 145 fpm	12 000 kg	@ 44 m/min
		3	11,025 lbs	@ 300 fpm	5 000 kg	@ 91 m/min
		4	2,205 lbs	@ 760 fpm	1 000 kg	@ 232 m/min
Hoist Unit	WiW 301 RX 005	2-Part Line (High Speed)				
147 hp (110 kW) DC hoist unit Ward Leonard 4-speed gearbox Electromagnetic gear shifting LS226		Gear	Capacity	Line Speed	Capacity	Line Speed
		1	22,045 lbs	@ 115 fpm	10 000 kg	@ 35 m/min
		2	13,230 lbs	@ 190 fpm	6 000 kg	@ 58 m/min
		3	6,000 lbs	@ 400 fpm	2 720 kg	@ 122 m/min
		4	1,650 lbs	@ 1,000 fpm	750 kg	@ 305 m/min

Motor Information

Drive Unit	Horsepower	Kilowatts	Speed	
Swing	2 x 10 hp	2 x 7.5 kW	0.6 rpm	
Trolley	12.3 hp	9.2 kW	65 – 130/130 – 260 fpm	20m – 40m/40m – 80m /min
Travel	2 x 14.2 hp	2 x 10.6 kW	82 fpm	25.0m/min













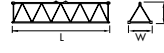

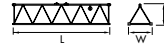

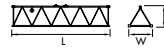
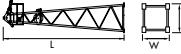
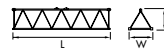
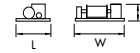

Power Requirements

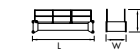
480 Volts — 3-phase — 60-cycle	275 Amperes service with 147 hp (110 kW) DC hoist units
--------------------------------	---

Specifications subject to change without notice. For other configurations and specifications, contact Morrow Equipment.

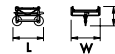
Component List

LIEBHERR 301 C

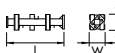
Description	Dimensions L x VV x H	Weight	Description	Dimensions L x VV x H	Weight
Outer Tower Section ¹ 301C	 28'-0" x 10'-0" x 3'-0" 8.53m x 3.05m x 0.9m	13,615 lbs 6 175 kg	Jib Section ① (611)	 33'-10" x 6'-11" x 7'-10" 10.3m x 2.1m x 2.4m	8,200 lbs 3 720 kg
Bottom Climbing Unit with Hydraulics	 38'-1" x 8'-6" x 8'-6" 11.6m x 2.6m x 2.6m	24,030 lbs 10 900 kg	Jib Section ② (621)	 34'-1" x 6'-11" x 7'-7" 10.4m x 2.1m x 2.3m	5,510 lbs 2 500 kg
Inner Tower Section (A-Section)	 26'-3" x 8'-6" x 8'-6" 8.0m x 2.6m x 2.6m	7,915 lbs 3 590 kg	Jib Section ③ (622)	 34'-1" x 6'-11" x 7'-7" 10.4m x 2.1m x 2.3m	5,005 lbs 2 270 kg
Inner Tower Section (C-Section)	 23'-4" x 8'-6" x 8'-6" 7.1m x 2.6m x 2.6m	13,340 lbs 6 050 kg	Jib Section ④ (623)	 34'-1" x 6'-11" x 7'-7" 10.4m x 2.1m x 2.3m	5,360 lbs 2 430 kg
Slewing Assembly ² (Complete)	 18'-1" x 7'-9" x 9'-6" 5.5m x 2.35m x 2.9m	23,810 lbs 10 800 kg	Jib Section ⑤ (631)	 34'-1" x 6'-11" x 7'-7" 10.4m x 2.1m x 2.3m	4,600 lbs 2 085 kg
Tower Top (Complete)	 30'-4" x 7'-5" x 7'-5" 9.25m x 2.25m x 2.25m	7,935 lbs 3 600 kg	Jib Section ⑥ (632)	 34'-1" x 6'-11" x 7'-7" 10.4m x 2.1m x 2.3m	3,200 lbs 1 450 kg
DC Hoist Unit ³ (147 hp/110 kW)	 9'-10" x 14'-8" x 4'-4" 3.0m x 4.47m x 1.32m	24,250 lbs 11 000 kg	Jib Section ⑦ (641)	 17'-1" x 7'-5" x 8'-0" 5.2m x 2.25m x 2.45m	1,800 lbs 815 kg
Counterjib Section 1 (Inner)	 21'-0" x 7'-3" x 6'-7" 6.4m x 2.2m x 2.0m	9 480 lbs 4 300 kg	Jib Assembly ⁵ 213-ft (65.0m) jib	①②③④⑤⑥⑦ 214'-3" x 7'-5" x 8'-0" 65.3m x 2.25m x 2.45m	44,560 lbs 20 200 kg
Counterjib Section 2 (Intermediate)	 17'-5" x 7'-3" x 2'-4" 5.3m x 2.2m x 0.7m	6,395 lbs 2 900 kg	Jib Assembly ⁵ 180-ft (55.0m) jib	①②③④⑤⑦ 181'-5" x 7'-5" x 8'-0" 55.3m x 2.25m x 2.45m	40,215 lbs 18 230 kg
Counterjib Section 3 (Outer) ⁴	 29'-0" x 8'-2" x 5'-7" 8.85m x 2.5m x 1.7m	34,610 lbs 15 700 kg	Jib Assembly ⁵ 148-ft (45.0m) jib	①②④⑤⑦ 148'-7" x 7'-5" x 8'-0" 45.3m x 2.25m x 2.45m	34,240 lbs 15 540 kg
Counterjib A (Complete) 72-ft (22.0m)	 65'-7" x 8'-2" x 6'-7" 20.0m x 2.5m x 2.0m	53,350 lbs 24 200 kg	Jib Assembly ⁵ 115-ft (35.0m) jib	①②④⑦ 115'-10" x 7'-5" x 8'-0" 35.3m x 2.25m x 2.45m	28,700 lbs 13 010 kg
Counterjib B (Complete) 56-ft (17.0m)	 49'-2" x 8'-2" x 6'-7" 15.0m x 2.5m x 2.0m	46,075 lbs 20 900 kg	Trolley	 7'-10" x 7'-9" x 4'-7" 2.4m x 2.35m x 1.4m	1,610 lbs 730 kg
Counterweight Block A	 6'-8" x 8" x 8'-5" 2.03m x 0.2m x 2.57m	5,170 lbs 2 345 kg	Hook Block	 2'-9" x 4'-8" x 10" 0.84m x 1.42m x 0.25m	1,100 lbs 500 kg
Counterweight Block B	 6'-8" x 8" x 7'-5" 2.03m x 0.2m x 2.26m	4,520 lbs 2 050 kg	Outer Tower Anchor (ea.) 301C (4 per set)	 4'-7" x 1'-8" x 1'-8" 1.4m x 0.5m x 0.5m	385 lbs 175 kg

NOTE: Weights and dimensions are approximate. Scale components before lifting.

¹ Dimensions shown are for a stack of 4 tower section panels. Four (4) panels are required for each tower section (complete). Dimensions of a completely assembled tower section are 26'-3" x 10'-6" x 10'-6" (8.0m x 3.19m x 3.19m).

² Slewing Assembly includes operator's cabin, two (2) swing motors and slewing ring.

³ Hoist unit does not include hoist wire rope.

⁴ Counter jib section 3 (Outer) includes 147 hp (110 kW) hoist unit. Does not include hoist wire rope.

⁵ Jib Assemblies include jib sections, pins, pendant bars, trolley and hook block.



Morrow Equipment
C O M P A N Y, L. L. C.

3218 Pringle Road SE • P O Box 3306 • Salem OR 97302 USA • 503/585 5721 • Fax 503/363 1172



Branch Offices: Atlanta, GA • Chicago, IL • Denver, CO • Honolulu, HI • Houston, TX • Los Angeles, CA • Las Vegas, NV
Millwood, NY • San Francisco, CA • Seattle, WA • Miami, FL • Tampa, FL • Washington, DC • Sydney, Australia
Wellington, New Zealand • Vancouver, BC, Canada • Toronto, ON, Canada • Mexico City, Mexico • Monterrey, Mexico