

**Tower Crane / Grue à tour / Gru a torre  
Grúa torre / Guindaste de torre**

# Turmdrehkran 80 EL

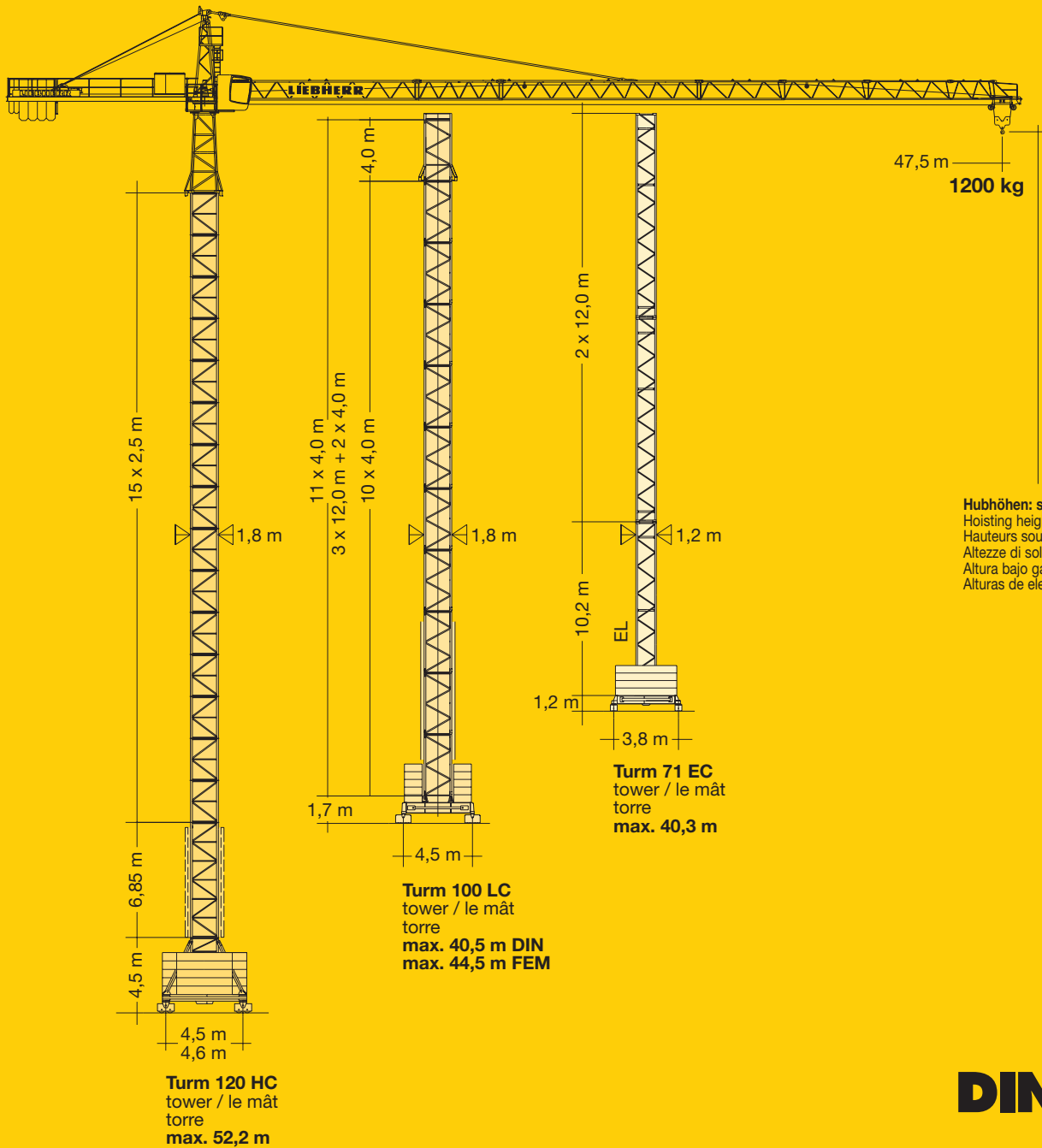

**DIN/FEM**

1 : 420

CD-1

# LIEBHERR

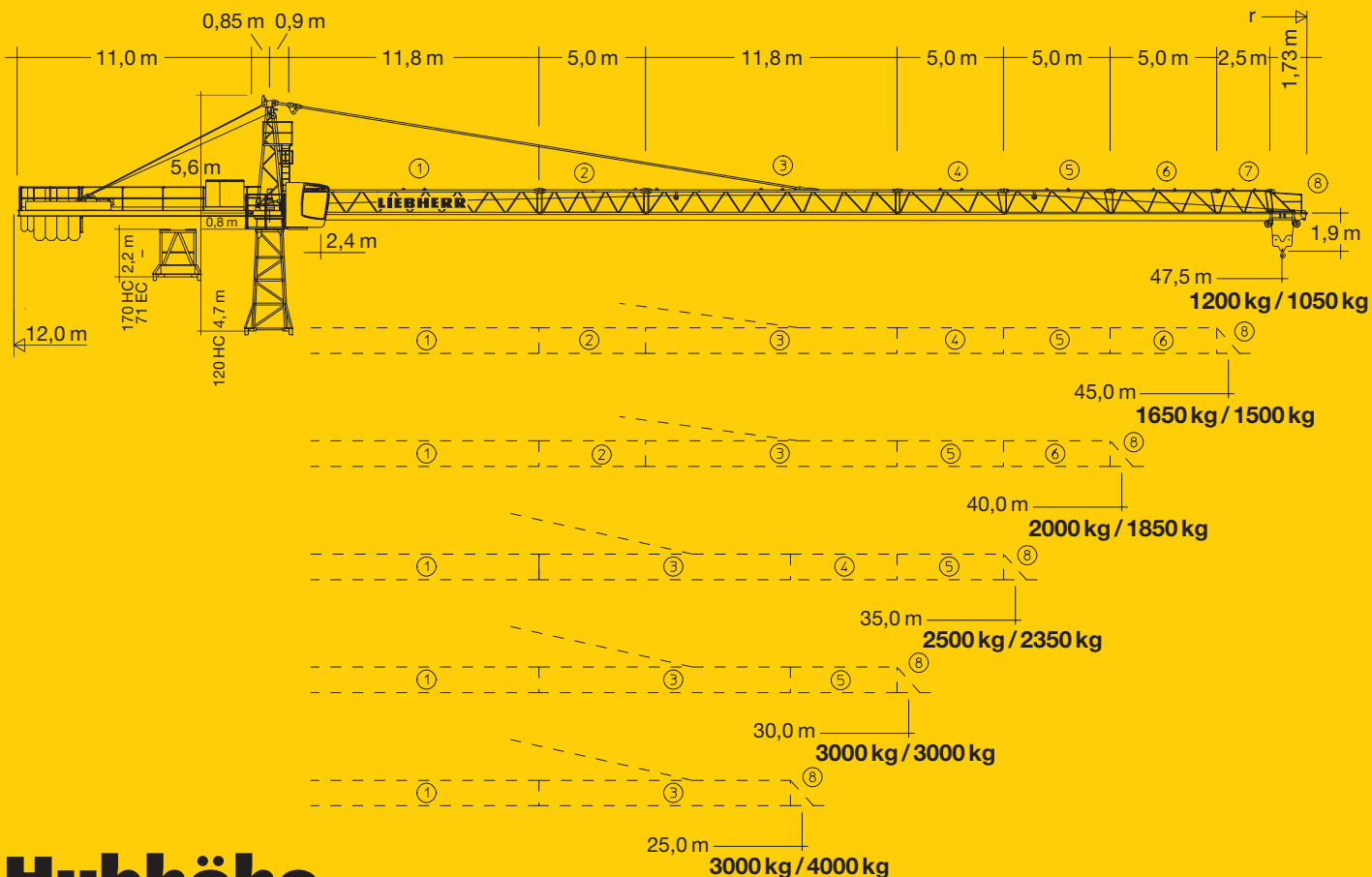

# Hubhöhe





Hoisting height / Hauteur sous crochet / Altezza di sollevamento / Altura bajo gancho / Altura de montagem

	120 HC		100 LC	
15	48,1*	52,4*	-	-
14	45,6	49,9	-	-
13	43,1	47,4	-	-
12	40,6	44,9	-	-
11	38,1	42,4	44,5* FEM	44,4* FEM
10	35,6	39,9	40,5*	40,4*
9	33,1	37,4	36,5	36,4
8	30,6	34,9	32,5	32,4
7	28,1	32,4	28,5	28,4
6	25,6	29,9	24,5	24,4
5	23,1	27,4	20,5	20,4
4	20,6	24,9	16,5	16,4
3	18,1	22,4	12,5	12,4
2	15,6	19,9	8,5	8,4
1	13,1	17,4	4,5	4,4
0	10,6	14,9	-	-
	m		m	

\* Weitere Hubhöhen sowie Klettern im Gebäude auf Anfrage. / Further hoist heights and climbing in the building on request.  
 Hauteurs sous crochet plus élevées et hissage dans le bâtiment sur demande. / Altre altezze di sollevamento come pure varianti di gru allungabili: su richiesta. / Para alturas bajo gancho superiores y trepado en el interior del edificio, consultar. / Outras alturas de elevação e subida no edifício: conforme ao pedido.

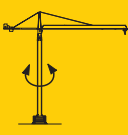
# Geschwindigkeiten

Speeds / Vitesse / Velocità / Velocidades / Velocidades

	U/min. sl./min tr./min 0,75	6,3 kW				
	12,0 / 43,0 / 85,0 m/min	3,0 kW				
	25,0 m/min	2 x 4,0 kW				
	<b>kVA</b>	<table border="1"> <tr> <td>22,0 kW</td> <td>22,0 kW, FU</td> </tr> <tr> <td>40,0</td> <td>30,0</td> </tr> </table>	22,0 kW	22,0 kW, FU	40,0	30,0
22,0 kW	22,0 kW, FU					
40,0	30,0					

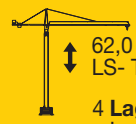
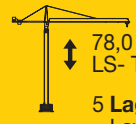
	Stufe / Step / Cran Marcia / Grado Velocidade	kg	m/min
 <p>22,0 / 18,0 / 4,0 kW, KL WIW 220 KY 006</p> <p>62,0 m LS- Trommel</p> <p><b>4 Lagen</b> Layers Couches strati camadas capas</p>	1	3000	3000
	2	3000	3000
 <p>22,0 kW, FU WIW 230 KY 002</p> <p>78,0 m LS- Trommel</p> <p><b>5 Lagen</b> Layers Couches strati camadas capas</p>	3	1500	1400
	4	1500	1400

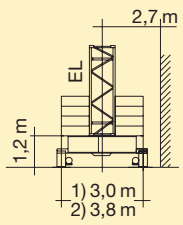
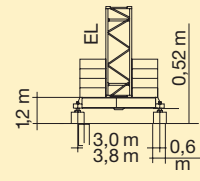
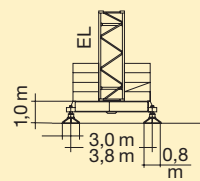
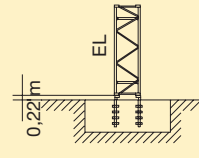
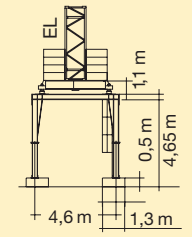
		<b>71 EC</b>				
6 m	12 m					
10,2 m	10,2 m					
* + Grundturmstück						
5		2) 34,3	40,3	40,1	39,3	45,7
4	2	-	30,1	29,9	29,1	34,9
3		1) 24,1	24,1	23,9	21,1	28,9
2	1	18,1	18,1	17,9	17,1	22,9
1		12,1	12,1	11,9	11,1	16,9
		6,1	6,1	5,9	5,1	10,9
		m	m	m	m	m
<b>Anzahl der Turmstücke</b> Number of tower sections Nombre d'éléments de mât N. elementi di torre Cant. secciones de torre Núm. de peças de torre						

\* Für die maximale Hakenhöhe ist das 10,2 m lange Grundturmstück erforderlich. / The 10,2 m long base tower section is necessary to achieve maximum hook height. / Pour obtenir la hauteur sous crochet maxi, il faut monter l'élément de mât de base d'une longueur de 10,2 m. Per ottenere l'altezza max. di gancio, si deve montare la sezione di torre basi di lunghezza 10,2 m. / Para la altura máxima bajo gancho se necesita el tramo base de 10,2 m. / Para alcançar à altura max. do gancho, é necessário utilizar a peça de base de torre de comprimento 10,2 m.

# Ausladung und Tragfähigkeit

Radius and capacity / Portée et charge / Sbraccio e portata / Alcances y cargas / Alcance e capacidade de carga

m	r	m/kg	m/kg															
			13,0	15,0	17,0	19,0	21,0	23,0	25,0	27,0	30,0	32,0	35,0	37,0	40,0	42,0	45,0	47,5
47,5	(r=49,0)	2,4-21,9 3000					3000	2840	2590	2380	2110	1960	1760	1640	1490	1410	1290	1200
45,0	(r=46,5)	2,4-26,8 3000					3000	3000	3000	2980	2650	2460	2220	2080	1900	1790	1650	
40,0	(r=41,5)	2,4-28,0 3000					3000	3000	3000	3000	2780	2590	2340	2190	2000			
35,0	(r=36,5)	2,4-29,7 3000					3000	3000	3000	3000	2970	2770	2500					
30,0	(r=31,5)	2,4-30,0 3000					3000	3000	3000	3000	3000							
25,0	(r=26,5)	2,4-25,0 3000					3000	3000	3000									



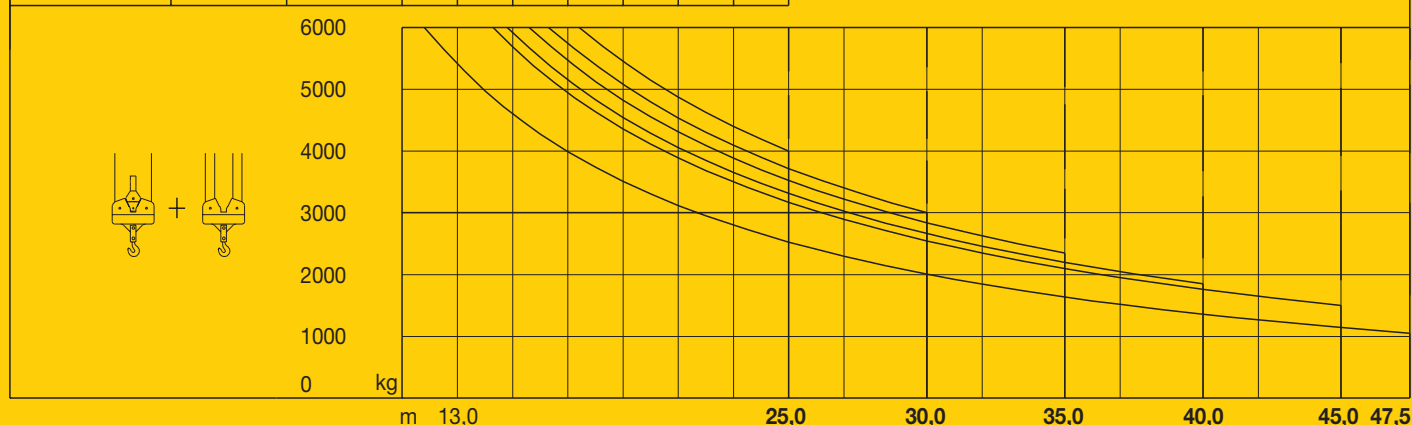

m	r	m/kg	m/kg																
			13,0	15,0	17,0	19,0	21,0	23,0	25,0	27,0	30,0	32,0	35,0	37,0	40,0	42,0	45,0	47,5	
47,5	(r=49,0)	2,4-21,7 3000	2,4-11,8 6000	5400	4600	3990	3510	3120	2800	2530	2300	2010	1840	1640	1520	1360	1270	1140	1050
45,0	(r=46,5)	2,4-26,2 3000	2,4-14,3 6000	6000	5680	4940	4360	3890	3500	3170	2890	2550	2350	2100	1950	1760	1650	1500	
40,0	(r=41,5)	2,4-27,2 3000	2,4-14,8 6000	6000	5920	5150	4550	4060	3650	3310	3020	2660	2460	2200	2050	1850			
35,0	(r=36,5)	2,4-28,7 3000	2,4-15,6 6000	6000	6000	5460	4830	4310	3880	3530	3220	2840	2630	2350					
30,0	(r=31,5)	2,4-30,0 3000	2,4-16,3 6000	6000	6000	5750	5080	4540	4090	3720	3400	3000							
25,0	(r=26,5)	2,4-25,0 3000	2,4-17,4 6000	6000	6000	6000	5450	4870	4400	4000									



## Kolli-Liste

Packing List / Liste de colisage / Lista dei colli  
Lista de contenido / Lista de embalagem

Montagegewichte: siehe Betriebsanweisung.  
Erection weights: see instruction manual.  
Poids de montage: voir manuel de service.  
Pesi di montaggio: vedasi le istruzioni sull'uso.  
Pesos de montagem: vejam-se as instruções p. uso.  
Peso para el montaje: según manual.

Kranoberteil			Upper part of crane / Partie supérieure de gru Parte superiore della gru / Parte superior grúa Parte superior do guindaste				L (m)	B (m)	H (m)	kg
Pos. Item Rep. Voce Pos. Ref.	Anz. Qty. Qté. Qta. Cant.	Komplettkrankopf / One-piece machine deck / Tête de grue Testa completa della gru Módulo giratorio / Cabeça compl. de guindaste			14,60					
1	1				12,80	2,44	2,62	7700		
2	1	Kabine mit Podest / Cabin with platform / Cabine avec plate-forme Cabina con piattaforma / Cabina con plataforma / Cabina con plataforma			4,20	1,35	2,20	950		

CD

## Technische Daten

Technical data - Caractéristiques techniques

Caratteristiche tecniche - Características técnicas - Datos técnicos

Pos. Anz.  
Item Qty.  
Rep. Qte.  
Voce Qta.  
Pos. Cant.  
Ref. Cant.

Einzelgewichte / Single  
weights / Poids individuels.  
Pesi di componenti.  
Pesos de peças componentes.  
Pesos unitarios.

					L (m)	B (m)	H (m)	kg
3	1	<b>Übergangsstück / Adapter section</b> Tronçon de conversation / Spezzone collegamento / Tramo de adaptación Peça ligadora			120 HC 5,00 170 HC 2,41 185 HC 2,41 256 HC 2,41	2,20 2,50 2,70 2,70	2,30 2,30 2,40 2,40	2540 2750 3170 3170
4	1	<b>Drehbühne kpl. / Slewing platform cpl.</b> Ensemble mât cabine cpl. / Piattaforma girevole compl. / Conjunto plataforma de giro / Plataforma giratória compl.			2,05	1,75	2,45	2550
5	1	<b>Turmspitze + Teilabspannung / Tower head section + first suspension bars / Porte-flèche + premiers tirants / Cuspide + tiranti / Cabeça de torre + tirante de fijación / Cabeça de torre + parte de acessórios de ancoragem</b>			5,30	1,40	1,70	1000
6	1	<b>Gegenausleger kpl. mit Ballastrahmen / Counter-jib cpl. with ballast frame / Contre-flèche cpl. avec cadre de lest / Contro- freccia con telaio di contrappeso / Conjunto plataforma con bastidor contrapeso / Contra-lança compl. com quadro de contrapeso</b>			L1 11,10	2,00	2,55	3450
7	1	<b>Ausleger-Anlenkstück + Teilabspannung / Jib heel section + first suspension bars / Pied de flèche + premiers tirants / 1 Ele- mento freccia + tiranti parziale / Tramo pie de pluma + Tirante de fijación / Base articulada da lança + parte de acessórios de ancoragem</b>			11,97	1,15	1,50	① 1600
8	1	<b>Ausleger-Zwischenstück + Abspannung</b> Intermediate jib section + suspension bars / Élément intern. de flèche + tirants / Elementi intermedi braccio + tiranti / Tramo intermedio de pluma + tirantes			5,20 12,00 5,20 5,20 5,20	1,02 1,02 1,02 1,02 1,02	1,50 1,50 1,25 1,25 1,25	② 590 ③ 1350 ④ 350 ⑤ 290 ⑥ 220
9	1	<b>Ausleger-Kopfstück / Jib head</b> Pointe de flèche / Punta freccia Cabeça de lança / Tramo punta de pluma			2,70 1,80	1,02 1,02	1,25 1,40	⑦ 120 ⑧ 125

## Turm Tower / Mât / Torre Torre / Torre

11		<b>Turmstück / Tower section</b> Element de mât / Elemento di torre Torre / Torre			71 EC 3,00 120 HC 6,00 120 HC 2,50 120 HC 5,00 170 HC 4,14	1,20 1,20 1,80 1,80 1,90	1,20 1,20 1,80 1,80 1,90	1080 1480 1090 1830 1850
12		<b>Turmstück lang / Long tower section</b> Élément de mât long / Elemento di torre, lungo / Tramo de torre largo / Peça de torre, comprida			71 EC 12,00 120 HC 10,00	1,20 1,80	1,20 1,80	2610 3425
13	1	<b>Grundturmstück / Base tower section</b> Mât de base / Elemento di torre base Tramo torre base / Peça de base de torre			71 EC 4,20 120 HC 6,85 120 HC 10,00 170 HC 9,60	1,20 1,80 1,80 1,90	1,20 1,80 1,80 1,90	1340 2610 3530 4350

## Klettereinrichtung Climbing equipment / Equipement de télescope / Attrezzatura per allungamento della gru Equipo de trepado / Acessórios p. subida no edifício



14	1	<b>Führungsstück kpl. / Guide section cpl.</b> Cage télescopique cpl. / Gabbia de sopraelevazione compl. / Peça de guia compl. / Torre de montagem completa			120 HC 6,45 120 HC 9,60 170 HC 9,04	2,10 2,10 2,31	2,42 2,42 2,28	2660 4410 4750
15	1	<b>Hydraulikanlage, Stütz- und Klettertraverse / Hydraulic unit, supporting and climbing cross members / Système hydraulique avec traverses d'appui et de télescope / Sistema idraulico, traversa di appoggio e allungamento gru / Instalação hidráulica, travessa de apoio e subida Sistema hidráulico con travessa de apoyo y trepado</b>			120 HC 2,87 170 HC 2,30	2,12 1,10	1,06 1,00	1800 1100

## Unterwagen Undercarriage / Châssis / Carro della gru Carro con mástil / Carro de guindaste

16	2	<b>Fahrschemel mit Antrieb / Rail bogie with drive / Bogie moteur / Telaio con gruppo propulsore / Quadro sem grupo de propulsão / Caja rodillo motriz</b>			71 EC 0,75 120 HC 1,38 170 HC 1,46	0,55 0,88 0,84	0,55 0,87 0,87	307 900 920
17	2	<b>Fahrschemel ohne Antrieb / Rail bogie without drive / Bogie fou / Telaio senza gruppo propulsore / Quadro com grupo de propulsão / Caja rodillo conducido</b>			71 EC 0,65 120 HC 1,17 170 HC 1,15	0,30 0,60 0,60	0,55 0,87 0,87	222 860 880
18	1	<b>Tragholm lang / Long support arm</b> Longeron long / Longherone lungo Brazo largo soporte / Travessa comprida			120 HC 7,12 170 HC 7,15	0,75 0,80	0,65 0,70	950 1070
19	2	<b>Tragholm kurz / Short support arm</b> Longeron court / Longherone corto Brazo corto soporte / Travessa curta			120 HC 3,45 170 HC 3,45	0,56 0,60	0,55 0,70	408 500
20	4 2 + 2	<b>Randträger / Border support</b> Traverse / Supporti base Traviesa / Apoio de bordo			120 HC 4,02 170 HC 4,08 - 4,30	0,35 0,16 - 0,33	0,12 0,11 - 0,14	95 80 - 200
21	4	<b>Stützholm / Support strut</b> Hauban de châssis / Correnti di appoggio Tirante vertical / Travessa de apoio			120 HC 3,78 170 HC 3,53	0,15 0,25	0,22 0,17	200 240
22	1	<b>Unterwagen-Turmstück / Undercarriage tower section / Mât de châssis / Elemento di torre del carro / Tramo de carro Peça de torre do chassis</b>			120 HC 3,50 170 HC 3,30	2,06 2,15	2,06 2,15	1320 2000

Pos. Anz.  
Item Qty.  
Rep. Qté.  
Voce Qta.  
Pos. Cant.  
Ref. Cant.

Einzelgewichte. / Single  
weights. / Poids individuels.  
Pesi di componenti.  
Pesos de peças componentes.  
Pesos unitarios.

					L (m)	B (m)	H (m)	kg
23	2	<b>Fundamentkreuz mit Spindeln, Tragholm lang /</b> Cruciform base with outrigger jacks, long support arm / <b>Châssis en croix avec vérins, longeron long /</b> Base incrociata con aste, longherone lungo / <b>Tramo largo base cruciforme, con husillos</b> Base cruciforme com árvores, travessa comprida		71 EC	3,8 m 5,80 3,0 m 4,70	0,60 0,60	0,80 0,80	1860 1625
24	2	<b>Fundamentkreuz fahrbar, Tragholm lang /</b> Cruciform rail going, long support arm / <b>Châssis en croix roulant, longeron long /</b> Base incrociata mobile, longherone lungo / <b>Brazo soporte largo de base cruciforme para traslación sobre vía</b> Base cruciforme móvel, travessa comprida		71 EC	3,8 m 5,60 3,0 m 4,50	0,60 0,60	0,90 0,90	1750 1510
25	4	<b>Fundamentkreuz fahrbar, Randträger /</b> Cruciform rail going, border support / <b>Châssis en croix roulant, traverse</b> Base incrociata mobile, traversa / <b>Traviesa de base cruciforme /</b> Base cruciforme móvel, apoio de bordo <b>(Fahrwerke wie Pos. 16 und 17) /</b> (Travel gears as under item 16 and 17) / <b>(Mécanismes de translation comme pos. 16 et 17) /</b> (Gruppi propulsori marcia come da voce 16 e 17) / <b>(Mecanismos de traslación como Pos. 16 y 17) /</b> (Grupos de propulsão de marcha: igual a ref. 16 et 17)		71 EC	3,8 m 3,40 3,0 m 2,60	0,20 0,20	0,35 0,35	114 91
26	1	<b>Kiste mit Kleinteilen /</b> Crate with small parts Caisse contenant des accessoires / <b>Cassa con accessori</b> Caja con accesorios / <b>Caixa de acessórios</b>		120 HC 170 HC	2,00	1,00	1,00	2000

121 P – 4348 H1 B3 DIN 15018 • BGL 2125-0080 / FEM (Section 1) Krangruppe A3 • 03.01 / 6

Konstruktionsänderungen vorbehalten! / Subject to alterations!  
Sous réserves de modifications! / Si fa riserva di modifiche!  
Salvo modificação da construação! / ¡Sujeto a modificaciones!

Printed in Germany.



**LIEBHERR-WERK BIBERACH GMBH, Postfach 1663, D-88396 Biberach an der Riß**  
☎ (0 73 51) 41-0, Fax (0 73 51) 41 22 25, [www.lbc.liebherr.de](http://www.lbc.liebherr.de), E-Mail: [info@lbc.liebherr.com](mailto:info@lbc.liebherr.com)